

Roll-Rite® Single Cable Series

Safe. Reliable. Automated Tarping.



Super Slider or Top Slider for Trucks & Trailers

Roll-Rite® Single Cable Series for automated tarping delivers unmatched safety, durability, and efficiency. Our continuous cable design provides the smoothest, most dependable jam-free operation—so you can secure every load and keep your business moving.



A Clarience Technologies Company

Quality, durable components engineered for tarping heavy duty trucks & trailers.

Single Cable Tarp Systems may include:



Electric Motor & Controller

- TarpMaster® gear motor with industry-leading 5-year non-prorated warranty
- An amp-sensing controller provides full motor protection
- Automatic shutdown if torque exceeds safe limits
- Remote control fob with extended-range antenna for safe operation from inside the cab or at a distance

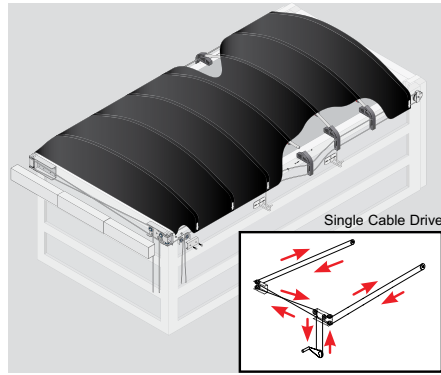

Single Cable Drive

- Smooth, synchronized operation with all bows attached to one cable
- Prevents rear bow misalignment and jamming
- One-piece continuous cable runs true to the side rail
- Single-bolt, ground-level cable tension adjustment
- Geared drive wraps around dual geared pulleys for better grip and reduced slippage



Pulleys

- Aluminum or zinc-plated steel components for superior rust protection
- One-piece V-grooved pulleys: billet machined, case hardened, zinc plated
- V-groove design improves cable grip and reduces slipping
- Rear pulley with forward-facing push-style tension adjustment to prevent binding
- Improved rear pulley placement minimizes incidental damage



Cable

- Heavy-duty 1/4" galvanized steel cable with 7x19 strand core for strength and minimal stretch
- Cable lengths custom-fit for each truck or trailer application



Bows

- 16-gauge, 1-1/8" galvanized steel bows for strength, durability, and corrosion resistance
- Sizes: 6", 12", 16" arches; 97.5", 102.5" or 106.5" widths for new systems. Replacement bows require cutting to size
- Easily replace bows or tarps without removing the cable



Bow Ends

- UHMW removable bow ends resist asphalt, UV exposure, and harsh weather
- Faster bow and tarp replacement with minimal downtime
- Replacing bow ends requires cable removal

Mounting Brackets & Bow Options:



Radius Nose Trailer Corner Kit



Radius Nose Trailer Motor Mounting Bracket



Bow Arches - 6", 12", 16" high & 97.5", 102.5", 106.5" widths



High Lift Gate Bow Option



SINGLE CABLE APPLICATIONS & BENEFITS

Roll-Rite Single Cable Series systems are ideal for transfer trucks with pups and end dump, belly dump and live bottom trailers:

- Low profile tarp operation reduces overhead clearance hazards and interference from windy conditions
- Electric drive allows tarp operation from the safety of the cab, even on pup trailers

SUPER SLIDER

The Super Slider SC System uses a single cable drive design for a smooth and jam-free operation. The bows are attached to the same cable, making it impossible for the rear bow to become misaligned.

- Weatherproof Design: The sliders bring the tarp down over the side rail about 5-1/4". This also prevents the tarp from whipping in the wind
- Clean Profile: Nice appearance with hidden sliders and cables



TOP SLIDER

The Top Slider SC System uses a single cable drive design with a tarp that covers the top of the opening. The UHMW sliders and single cable design make this the most dependable Top Slider cable system available.

- Longer Tarp Life: Heavy-duty webbing is sewn along the edge of the tarps to add wear protection in this critical area. The tarp lasts longer because it doesn't rub on the top rails
- High Lift Gate Bow Option: High lift Gate Bows for trucks or trailers with high-lift gates are available (see bottom of facing page)

Drive Options:

Roll-Rite offers drive options to suit your truck or trailer needs:

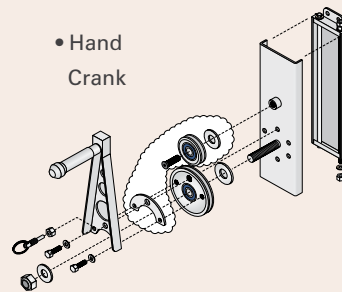
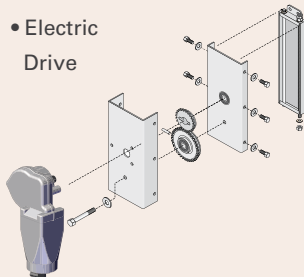

- Rite-Touch™ Electric Kit



Roll-Rite® Tarps



Fabric Note: Colors other than black may require additional lead times or costs.

THE CABLE TARPS:

- Seamless, single-piece construction with reinforcements in high wear areas provides a robust, longer life tarp
- Front of tarp tapers from front header to desired bow height, reducing drag and increasing fuel economy
- Rear finish options allow systems to be tailored to your trailer. 2-piece rear flap prevents bulldozing of load. Rear bonnet allows for fully automatic tarp operation
- Anti-Lift Hook Kits: universal kits prevent tarp from lifting due to wind
- Maximum Load Clearance: Tarp retracts to clear over 95% load zone

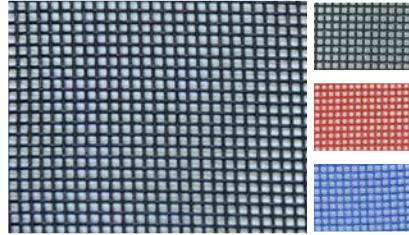

MESH

LOAD TYPE
Sand, Rock, Aggregates, Refuse

FABRIC
High-quality vinyl-coated polyester mesh

KEY BENEFIT
Open weave design allows air to flow through without billowing

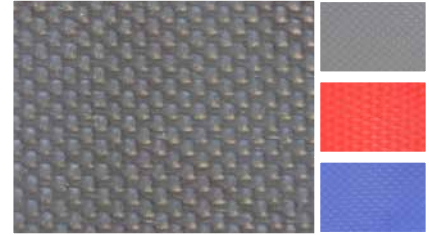

18 OZ VINYL

LOAD TYPE
Moisture or temperature sensitive, such as asphalt, scrap, grain, and fertilizer

FABRIC
18 oz. waterproof vinyl

KEY BENEFIT
Seamless full-width waterproof material used when loads need to be kept mostly dry or maintain a temperature range



Anti-Lift Hook Kits



Bolt-on 2-pc Back Flap



Rear Bonnet



Tapered Front



95% Load Clearance

Proud Members:



**LEARN MORE ABOUT
Single Cable Series:**



302-RR-Single-Cable-4PG-202601

TECHNOLOGY-DRIVEN
Automated Covering Solutions

Contact a Tarp Expert:
1.800.297.9905 | rollrite.com

