



# ELECTRICAL COMPONENT INSTALLATION GUIDE

Installation Requirements and Wiring Diagrams for Automated Tarp Systems Components

---

Part #: 105568

Revised: 02/27/26 - WLH



**Table of Contents**

Safety Requirements .....	1	Generation 1 Rite Touch® Solid State Reversing Relay with RF Switch Tarp Uncovering to the Right of Driver .....	20
Vehicle Battery Connection Requirements .....	2-5	Generation 1 Rite Touch® Solid State Reversing Relay with RF Switch Tarp Uncovering to the Left of Driver .....	21
Switch Requirements .....	6-7	Horizontal Trailer Plug Set .....	22
Roll Rite Motor Reversing Relay Types .....	8	Vertical Trailer Plug Set .....	23
Tarp System Orientation for Side to Side Systems .....	9	Troubleshooting the System .....	24-30
Mechanical Reversing Relay with Rocker Switch or Rotary Switch Tarp Uncovering to Right Side of the Driver .....	10		
Mechanical Reversing Relay with Rocker Switch or Rotary Switch Tarp Uncovering to Left Side of the Driver .....	11		
Mechanical Reversing Relay with RF Switch Tarp Uncovering to Right of the Driver .....	12		
Mechanical Reversing Relay with RF Switch Tarp Uncovering to Left of the Driver .....	13		
Generation 1 Rite Touch® Solid State Reversing Relay with Rocker or Rotary Switch .....	14		
Generation 1 Rite Touch® Solid State Reversing Relay with Rocker or Rotary Switch - Tarp Uncovering to Left of the Driver .....	15		
Generation 1 Rite Touch® Solid State Reversing Relay with Rocker or Rotary Switch - Tarp Uncovering to the Right of Driver .....	16		
Generation 1 Rite Touch® Solid State Reversing Relay with Rocker or Rotary Switch - Tarp Uncovering to the Left of the Driver .....	17		
Generation 1 Rite Touch® Solid State Reversing Relay with RF Switch Tarp Uncovering to the Right of Driver .....	18		
Generation 1 Rite Touch® Solid State Reversing Relay with RF Switch Tarp Uncovering to the Right of Driver .....	19		



## Safety Requirements



**Failure to comply with requirements outlined in this document may result in serious injury or property damage**

The following requirements shall be met when installing or servicing electrical components in Roll Rite Automated Tarp Systems:

- All connections to vehicle battery systems, vehicle battery chargers, and external power supplies shall be disconnected during all installation procedures
- Prior to installing wiring on positive terminals, check voltage on all wires and connection points using a voltmeter.
- The following personal protective equipment shall be worn at all times while installing components:
  - » Safety Glasses or Prescription Glasses with Side Shields
  - » Steel or Composite Toe Protective Shoes

## Tools and Equipment Required for Installation

The following tools are required for installation of electrical components

- Torque Wrench with range between 20 in lbs to 150 in lbs
- Nut Driver Set
- Wire Cutters up to 2AWG size wire
- Wire Insulation Stripping Tool for wire size range from 2 to 8 AWG
- Wire Insulation Stripping Tool for wire size range from 16 to 18 AWG
- Wire Terminal Crimping Tool for wire size range from 2 to 8 AWG
- Wire Terminal Tool for wire size range from 16 to 18 AWG
- Heat Gun for application of heat shrink insulation
- Multi-meter with DC voltage measurement capability
- Tie Straps
- Vehicle Chassis Wiring insulated c-clamps capable of carrying 2 to 8 AWG wiring



## Vehicle Battery Connection Requirements

### Main Power to Roll Rite System

- Source Voltage Line to Motor Reversing Relay shall be connected directly to the vehicle battery system.
- The Source Voltage Line shall include an in-line Roll Rite supplied manually resettable circuit breaker. The circuit breaker should be 12" max from the positive terminal of the vehicle battery system.
- Main Power and Ground Connection through a power distribution box are forbidden.

### Main Ground to the Roll Rite System

- Ground line to the Motor Reversing Relay shall be connected directly to the negative terminal of the vehicle battery system
- Battery terminals shall be coated with dielectric grease to prevent corrosion
- Appropriate ring terminal or battery terminal at the vehicle battery connection are required

### System Circuit Breaker Requirements

- Only Roll Rite supplied Circuit Breakers shall be installed with Roll Rite Automated Tarp Systems
- The manually resettable circuit breaker shall be installed on the main positive wire, this should 12 inches max from the positive terminal of the vehicle battery system
- The circuit breaker shall be installed with red protective boots covering the input and output terminals
- Circuit Breaker shall be mounted on a vertical surface with the input and output wires entering and exiting from the sides. This is the only approved installation orientation for the circuit breaker.
- Terminals of the circuit breaker shall be no less than 2 inches from any surface on the vehicle in all directions

### Motor Reversing Relay Requirements



**Failure to properly follow all requirements may result in present or future property damage Roll-Rite Motor Reversing Relays contain a hot at all times connection to the vehicle battery system. Care must be taken to prevent contact between battery supply terminals and conductive surfaces of the chassis.**



## Vehicle Battery Connection Requirements

### Motor Reversing Relay Requirements



The positive terminal of Roll Rite Motor Reversing Relay is hot at all times, breaker connected to the positive terminal of the vehicle battery energy system. Care must be taken to ensure the positive terminals meet the following:

1. Connected only with the supplied fasteners to the correct torque (8-11 ft.lb) to prevent a loose, high-resistance connection, and Strain relieved to prevent wire torque and vibration from loosening connection
2. Completely covered with the proper Red terminal boot
3. Failure to comply may result in excessive heat in the connection due to high resistance

### Mechanical Reversing Relay Requirements (Part Number 10698)

- The Motor Reversing Relay shall be installed on a vertical plane with the wires from terminals (B+, B-, M2, M1) facing down. This is the only approved orientation of the motor reversing relay.
- Mount the relay in a location that it is protected from road debris, ice, snow, and road spray or bombardment
- Use the terminal boots supplied with the motor reversing relay, according to the following color codes:
- B+ is RED indicating the terminal is un-switched, fused, and hot at all times
- B- is Black
- M2 is Blue
- M1 is Yellow
- All terminals shall be coated with dielectric grease to prevent corrosion and long term connection from debris between electrical terminals
- Install the motor reversing relay such that the terminals are facing the vertical mounting surface on the vehicle body
- The motor reversing relay shall be attached to the surface using only threaded fasteners with torque specification consistent with the fastener size and type
- All terminal wires shall be strain relieved using insulated C-clamps attached to vehicle body to prevent wire vibration and torque loading from loosening electrical connections
- Route all electrical wires from the Motor Reversing Relay in a manner that will avoid wire insulation chafing, pinching, and wear from other items on the truck chassis or wear from the environment
- Torque all electrical connection fasteners to minimum 8-11 ft.lb



## Vehicle Battery Connection Requirements

### Motor Reversing Relay Requirements

#### Mechanical Reversing Relay Requirements (Part Number 10670)

- Mount the relay in a location that it is protected from road debris, ice, snow, and road spray or bombardment
- Use the terminal boots supplied with the motor reversing relay, according to the following color codes:
- B+ is RED indicating the terminal is un-switched, fused, and hot at all times
- B- is Black
- REV is Blue
- FWD is Yellow
- All terminals shall be coated with dielectric grease to prevent corrosion and long term connection from debris between electrical terminals
- Install the motor reversing relay such that the terminals are facing the vertical mounting surface on the vehicle body
- The motor reversing relay shall be attached to the surface using only threaded fasteners with torque specification consistent with the fastener size and type
- All terminal wires shall be strain relieved using insulated C-clamps attached to vehicle body to prevent wire vibration and torque loading from loosening electrical connections
- Route all electrical wires from the Motor Reversing Relay in a manner that will avoid wire insulation chafing, pinching, and wear from other items on the truck chassis or wear from the environment
- Torque all electrical connection fasteners to maximum 35 in lbs



## Vehicle Battery Connection Requirements

### Rite-Touch® Solid State Reversing Relay Requirements

- Rite-Touch® Solid State Reversing Relay Requirements
- The Motor Reversing Relay shall be installed on a vertical plane with the wires from terminals (B+, B-, M2, M1) facing down. This is the only approved orientation of the motor reversing relay.
- Mount the relay in a location that it is protected from road debris, ice, snow, and road spray or bombardment
- Use the terminal boots supplied with the motor reversing relay, according to the following color codes:
- B+ is RED indicating the terminal is un-switched, fused, and hot at all times
- B- is Black
- M2 is Blue
- M1 is Yellow
- All terminals shall be coated with dielectric grease to prevent corrosion and long term connection from debris between electrical terminals
- Install the motor reversing relay such that the terminals are facing the vertical mounting surface on the vehicle body
- The motor reversing relay shall be attached to the surface using only threaded fasteners with torque specification consistent with the fastener size and type
- All terminal wires shall be strain relieved using insulated C-clamps attached to vehicle body to prevent wire vibration and torque loading from loosening electrical connections
- Route all electrical wires from the Motor Reversing Relay in a manner that will avoid wire insulation chafing, pinching, and wear from other items on the truck chassis or wear from the environment
- Rite Touch® Solid State Motor Reversing Relays shall be installed with the new high strength plastic cover provided with the assembly.
- Spade terminals for switch signals shall be coated with dielectric grease to prevent corrosion
- Spade terminals from switch harness shall be fully seated on terminals
- Torque all electrical connection fasteners to minimum 8-11 ft.lb



## Switch Requirements

### Momentary Rocker Switch and Rotary Switch



**Roll Rite Rocker and Rotary switches contain hot-at-all-times connection at the center terminal of the switch. No exterior installation of the rocker or rotary switch is permitted. Contamination from an outside environment may connect the switch center input to the command line, resulting in unexpected movement of the tarp system**

- Use only a Roll Rite supplied Rocker Switch or Rotary Switch with the motor reversing relay
- Roll Rite switches shall be installed inside the cab of the vehicle only, using Roll Rite switch bracket
- Switch terminals shall be protected from contact with conductive materials
- Switch harness shall be fully insulated
- Switch spade terminal connections shall be fully seated, preventing exposed conductive surfaces
- Rocker switch shall be installed such that the switch labels read from left to right

### Radio Frequency (RF) Switch with Hand Held Transmitter

- RF switch shall be mounted with controller body connected to the Motor Reversing Relay, in the Motor Reversing Relay required orientation. No other orientation is permissible.
- Ring and spade terminals shall be fully seated with no conductive material exposed.
- Ring and spade terminals shall be coated with protective dielectric grease to prevent corrosion
- The RF Switch wires have insulated covers with the following colors corresponding to the connections;
  - » Red – Power from Positive Spade or Positive Stud on the Motor Reversing Relay
  - » Black – Ground from Negative Spade or Negative Stud on the Motor Reversing Relay
  - » Blue
    - REV Spade Terminal on the Rite Touch® Solid State Relay
    - S1 Spade Terminal on the Mechanical Relay
  - » Yellow –
    - FWD Spade Terminal on the Rite Touch® Solid State Relay
    - S2 Spade Terminal on the Mechanical Relay



## Switch Requirements

### Gear Motor Installation Requirements

- Changing operational direction of the Roll Rite shall be achieved by installing the motor terminals as described here:
  - » Side to Side System with Axle is on Driver Side When Fully Closed/Covered, and Front to Back with Motor on Driver Side of Vehicle
    - Yellow: M2, Positive Motor Terminal
    - Blue: M1, Negative Motor Terminal
  - » Side to Side system with Axle on Passenger Side when fully Closed/Covered, and Front to Back with Motor on Passenger Side of Vehicle
    - Yellow: M1, Negative Motor Terminal
    - Blue: M2, Positive Motor Terminal
- Gear Motor shall be mounted using all mounting locations provided
- Electric Motor connections shall be fully coated in dielectric grease
- Yellow and Blue Terminal boots shall be installed, fully covering the motor terminals
- Electric motor connection torque requirement: 15 to 22 in.lb
- To prevent terminal damage - Do not exceed 25.5 in.lb



# INSTALLATION GUIDE

Electrical Component

## Roll Rite Motor Reversing Relay Types

**NOTE: All views shown on this page are Terminal Side or Rear Views**

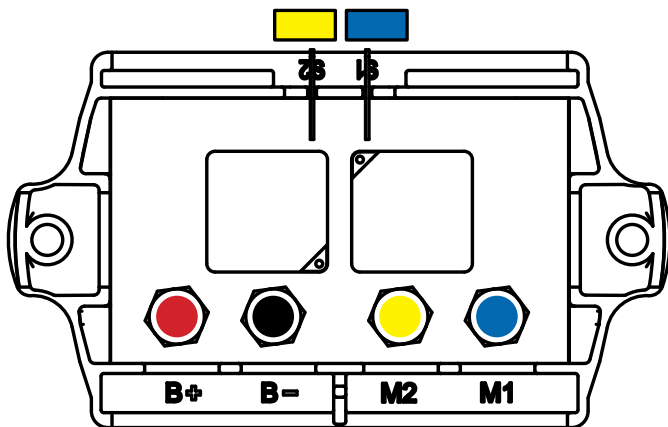

10698 Mechanical Motor Reversing Relay (Rear View)

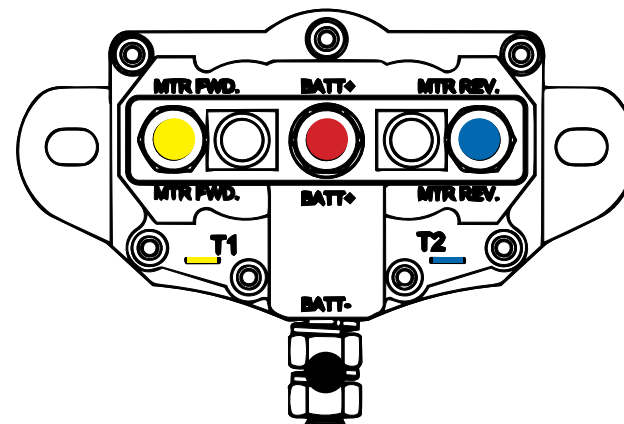

10670 Mechanical Motor Reversing Relay - Terminal View

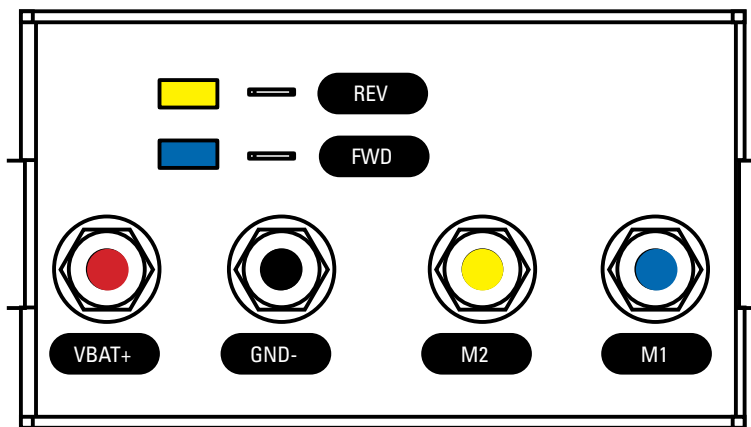

Generation 1 Rite Touch® Solid State Motor Reversing Relay (Rear View)

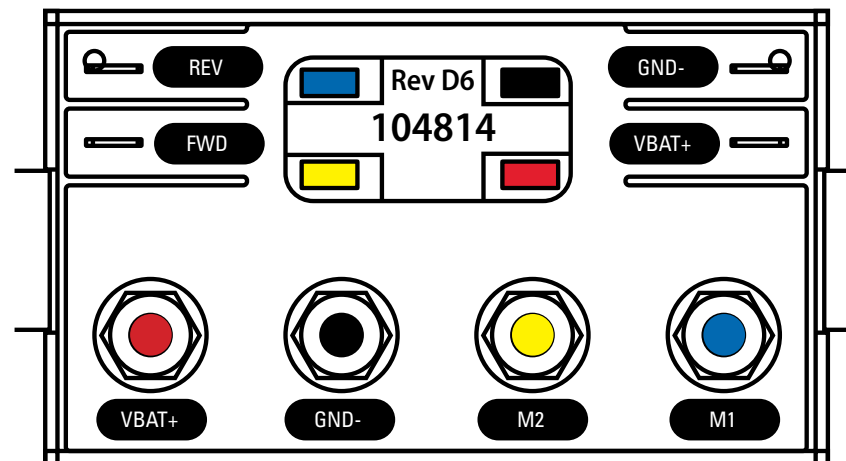

Generation 1 Plus Rite Touch® Solid State Motor Reversing Relay (Rear View)

**NOTE: All Views in wiring diagrams are front view, looking through the relay as if it were transparent**



### Tarp System Orientation for Side to Side Systems

The wiring diagrams are presented with the following two system orientations relative to driver facing forward in the vehicle

#### Left Side Uncovering

Tarp System is fully uncovered and the axle is on the left side of the driver.

Tarp System is fully covered and the axle is in lock-down position on to the right of the driver.

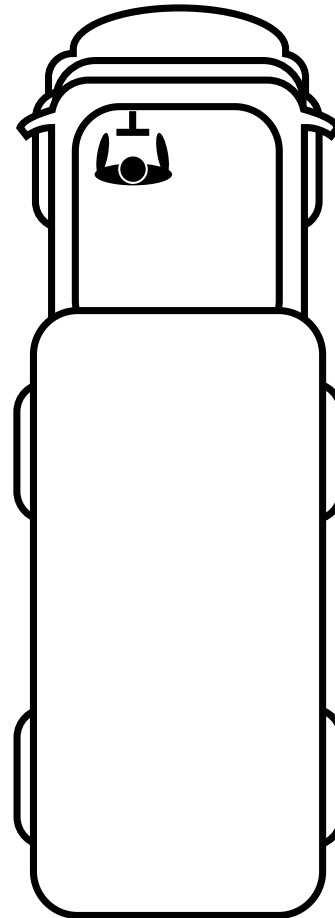

#### Right Side Uncovering

Tarp System is fully uncovered and the axle is on the right side of the driver.

Tarp System is fully covered and the axle is in lock-down position on to the left of the driver.



For Front to Back, flip style tarp systems, follow the orientation of the Right Side Opening Side to Side Systems.



# INSTALLATION GUIDE

# Electrical Component

## Mechanical Reversing Relay with Rocker Switch or Rotary Switch

Tarp Uncovering to Right Side of the Driver

- (16213) Red - Bat+
- (16206) Black - Bat - (GND)
- (16203) Yellow - M2
- (16202) Blue - M1

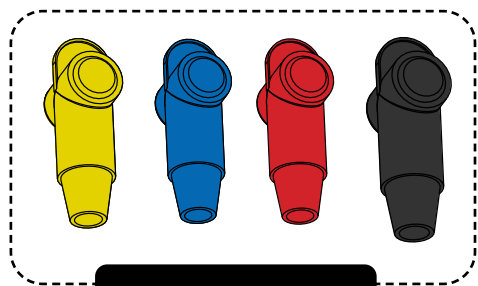

MECHANICAL RELAY BOOTS

- (16203) Yellow - M2+
- (16202) Blue - M1-

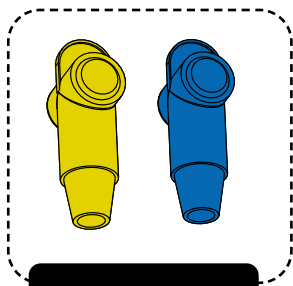

MOTOR CAP BOOTS

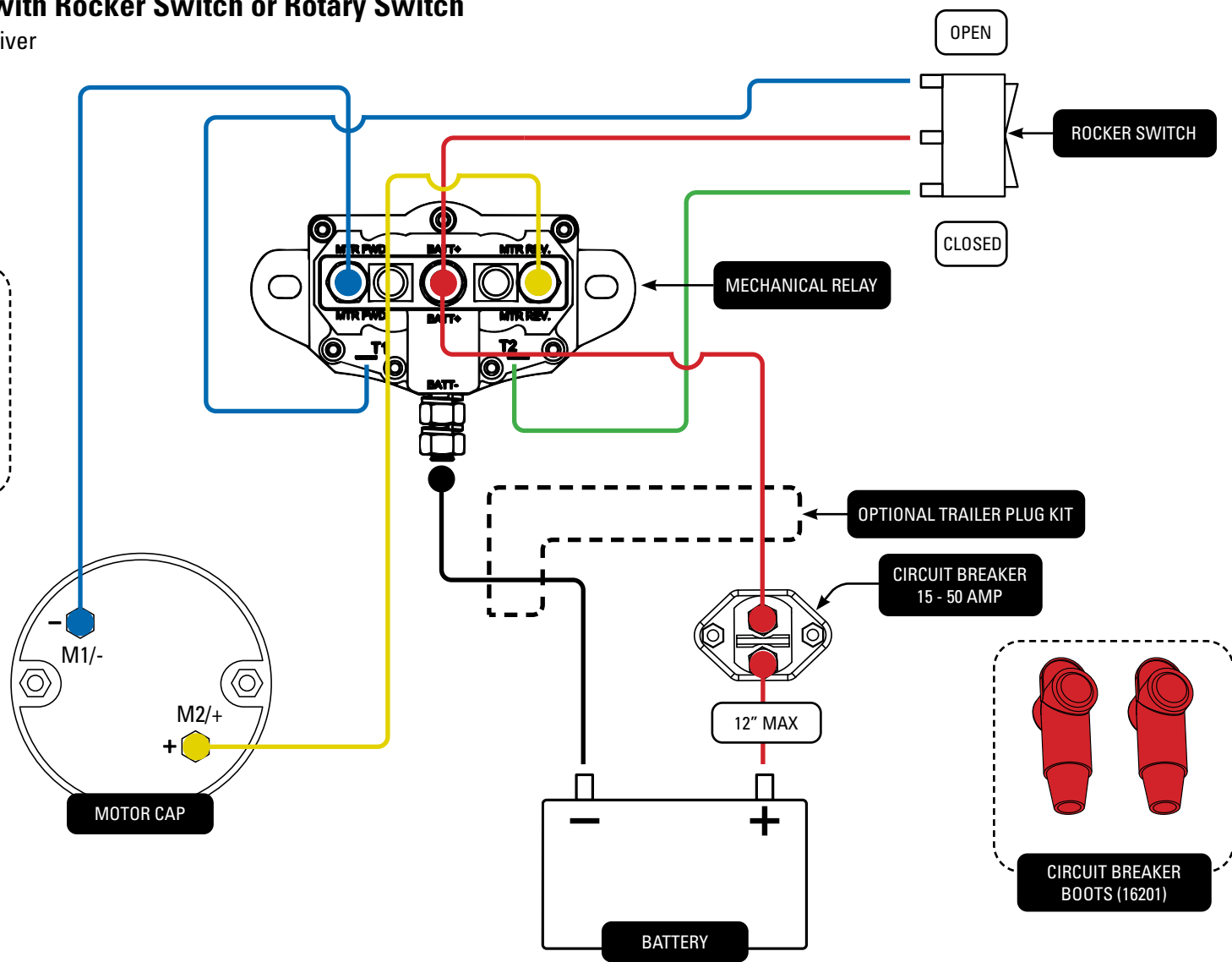



# INSTALLATION GUIDE

# Electrical Component

## Mechanical Reversing Relay with Rocker Switch or Rotary Switch

Tarp Uncovering to Left Side of the Driver

- (16213) Red - Bat+
- (16206) Black - Bat - (GND)
- (16203) Yellow - M2
- (16202) Blue - M1

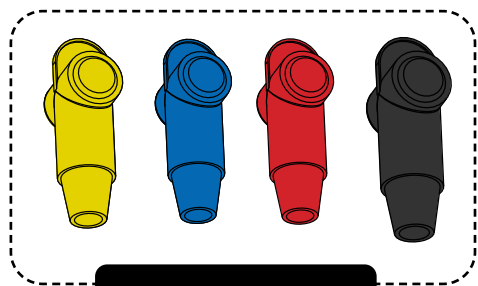

MECHANICAL RELAY BOOTS

- (16203) Yellow - M2+
- (16202) Blue - M1-

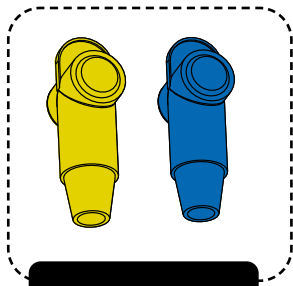

MOTOR CAP BOOTS

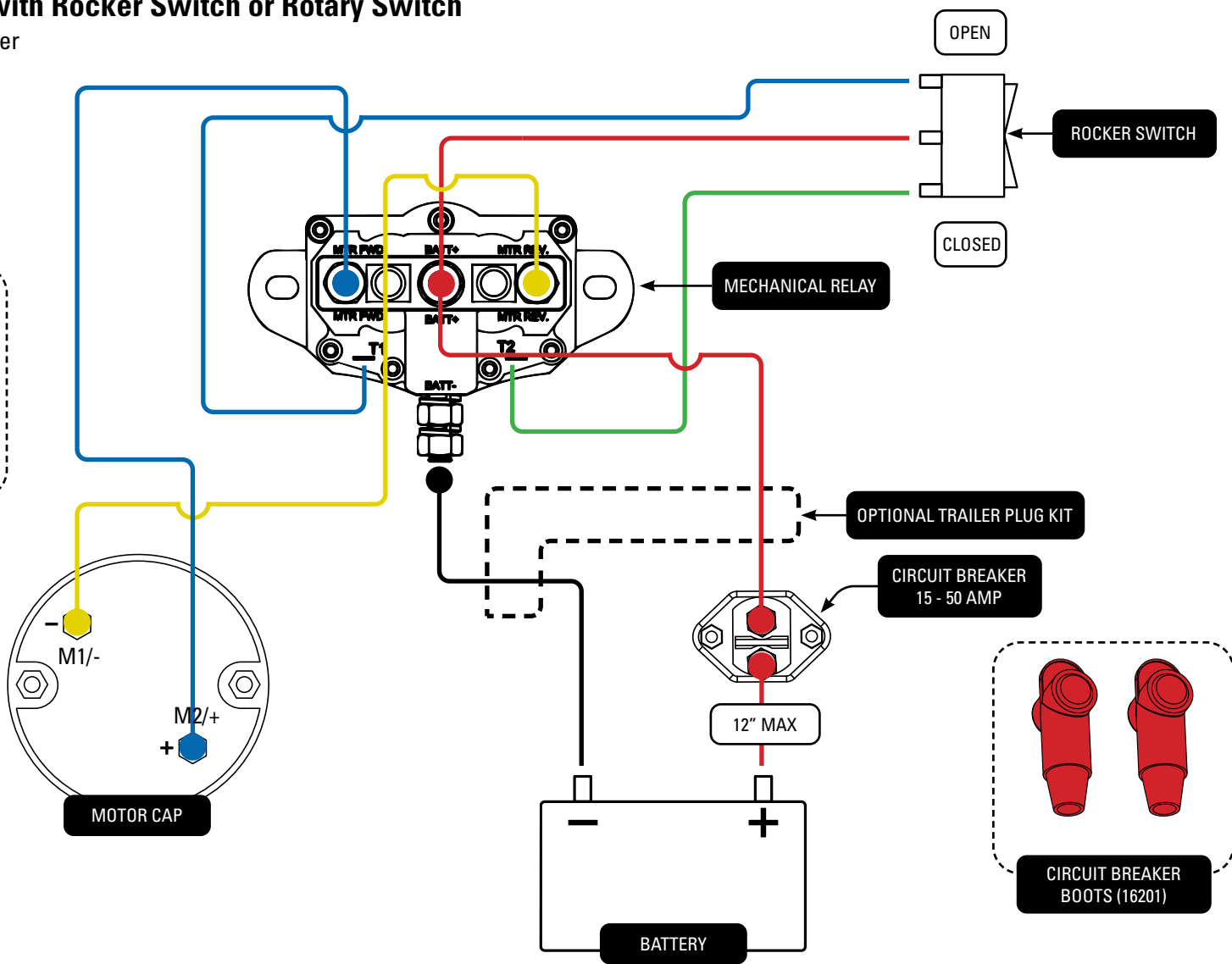



# INSTALLATION GUIDE

# Electrical Component

## Mechanical Reversing Relay with RF Switch

Tarp Uncovering to Right of the Driver

- (16213) Red - Bat+
- (16206) Black - Bat - (GND)
- (16203) Yellow - M2
- (16202) Blue - M1

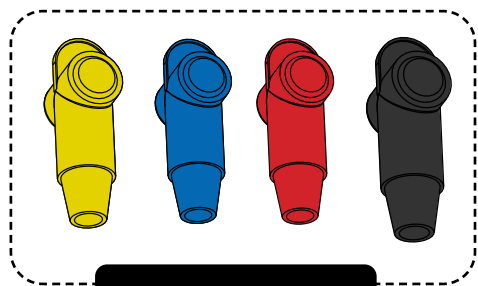

MECHANICAL RELAY BOOTS

- (16203) Yellow - M2+
- (16202) Blue - M1-

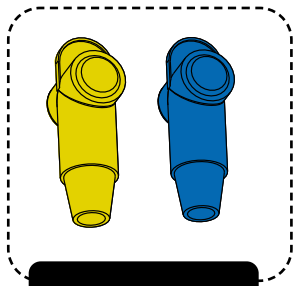

MOTOR CAP BOOTS

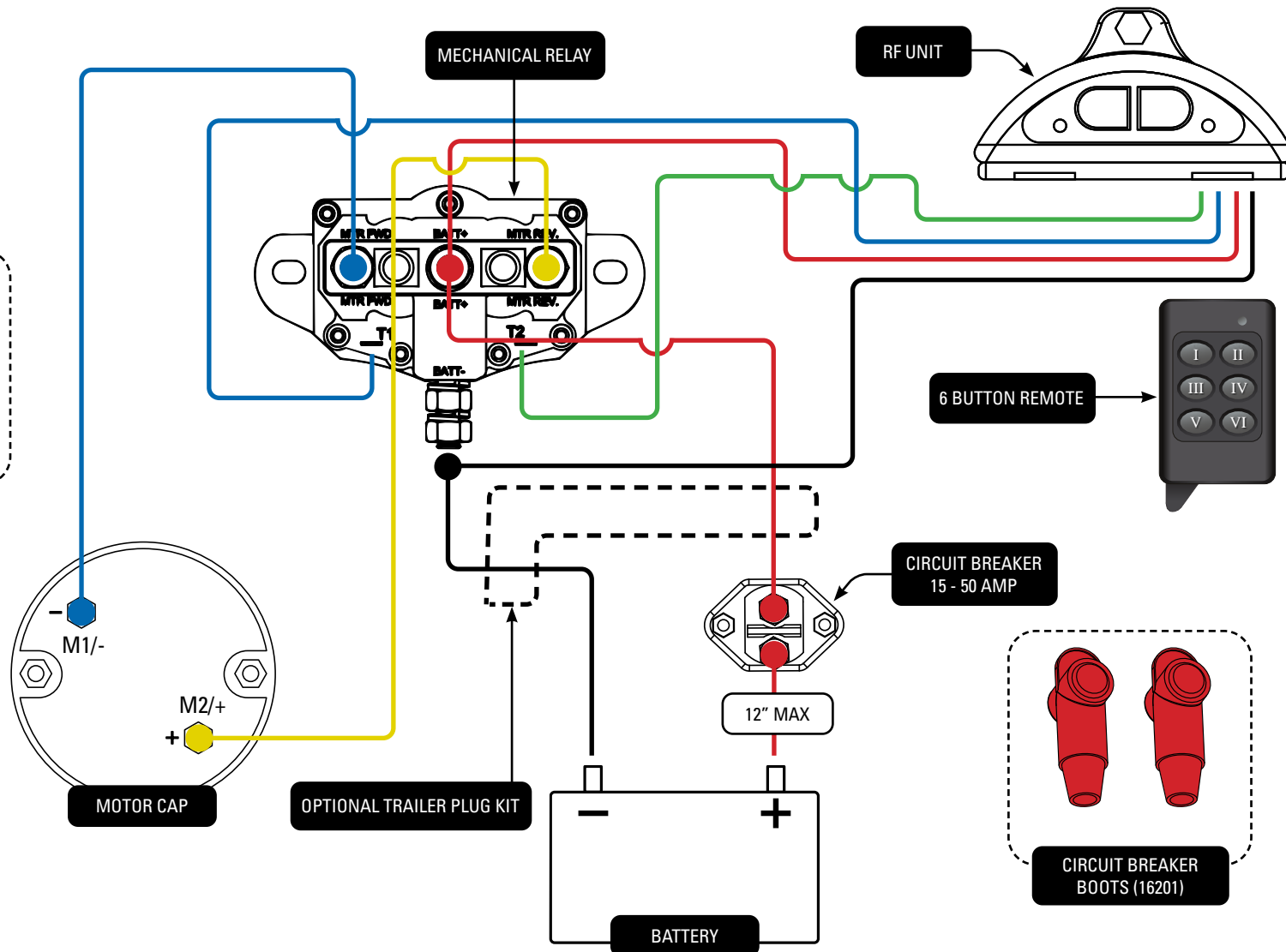



# INSTALLATION GUIDE

# Electrical Component

## Mechanical Reversing Relay with RF Switch

Tarp Uncovering to Left of the Driver

- (16213) Red - Bat+
- (16206) Black - Bat - (GND)
- (16203) Yellow - M2
- (16202) Blue - M1

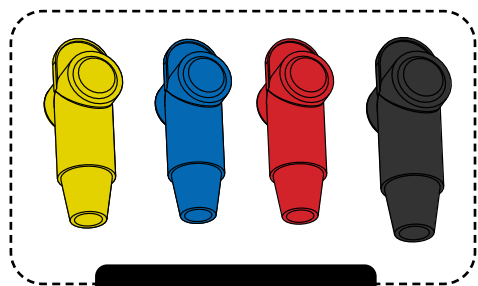

MECHANICAL RELAY BOOTS

- (16203) Yellow - M2+
- (16202) Blue - M1-

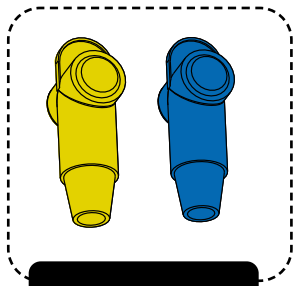

MOTOR CAP BOOTS

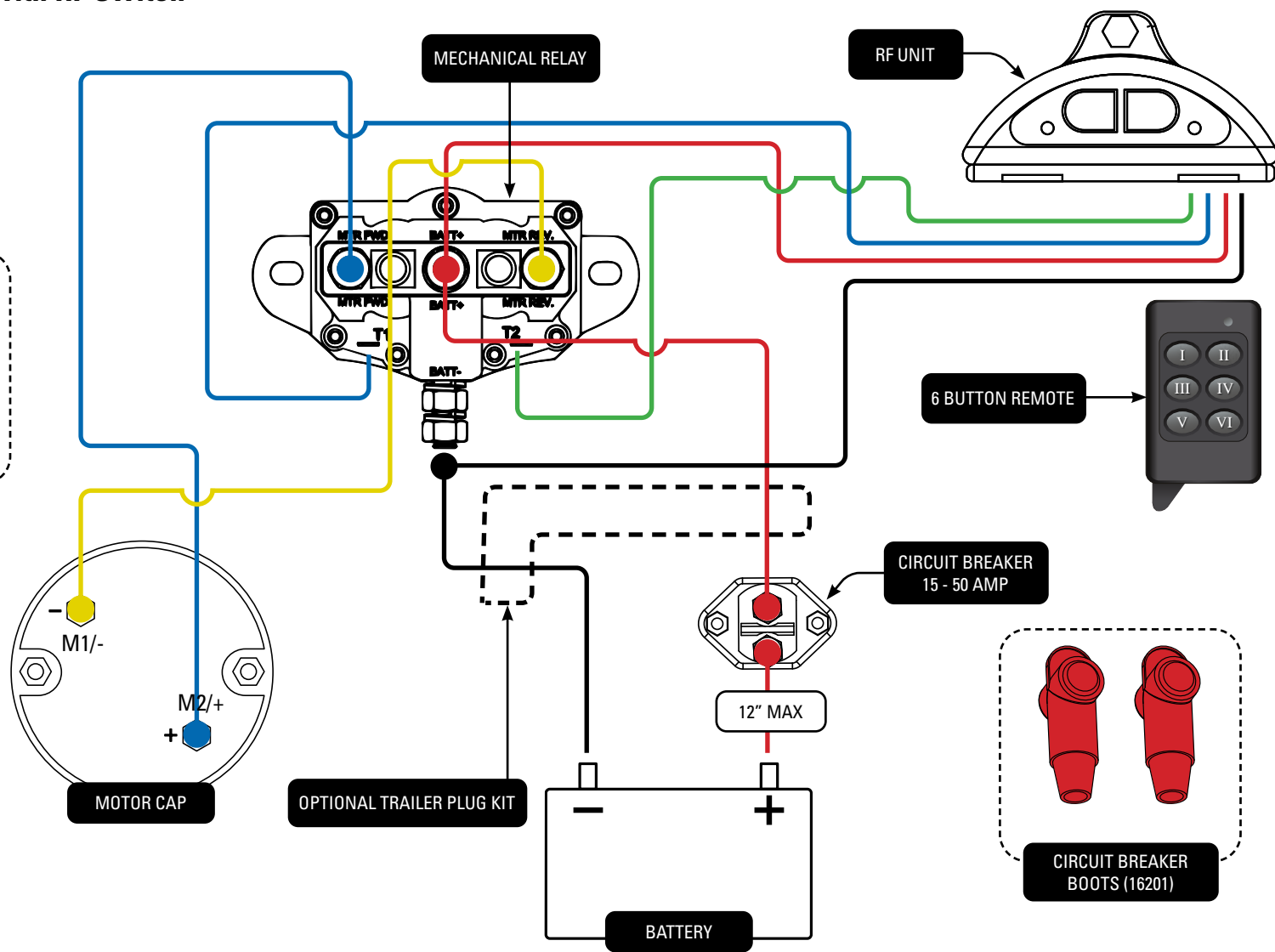



# INSTALLATION GUIDE

# Electrical Component

## Generation 1 Rite Touch® Solid State Reversing Relay with Rocker or Rotary Switch

- (16213) Red - Bat+
- (16206) Black - Bat - (GND)
- (16203) Yellow - M2
- (16202) Blue - M1

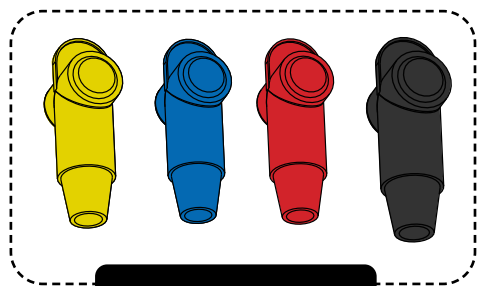

MECHANICAL RELAY BOOTS

- (16203) Yellow - M2+
- (16202) Blue - M1-

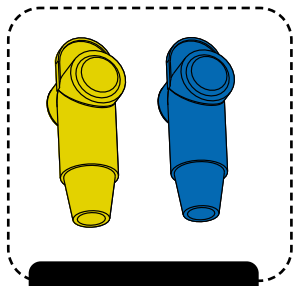

MOTOR CAP BOOTS

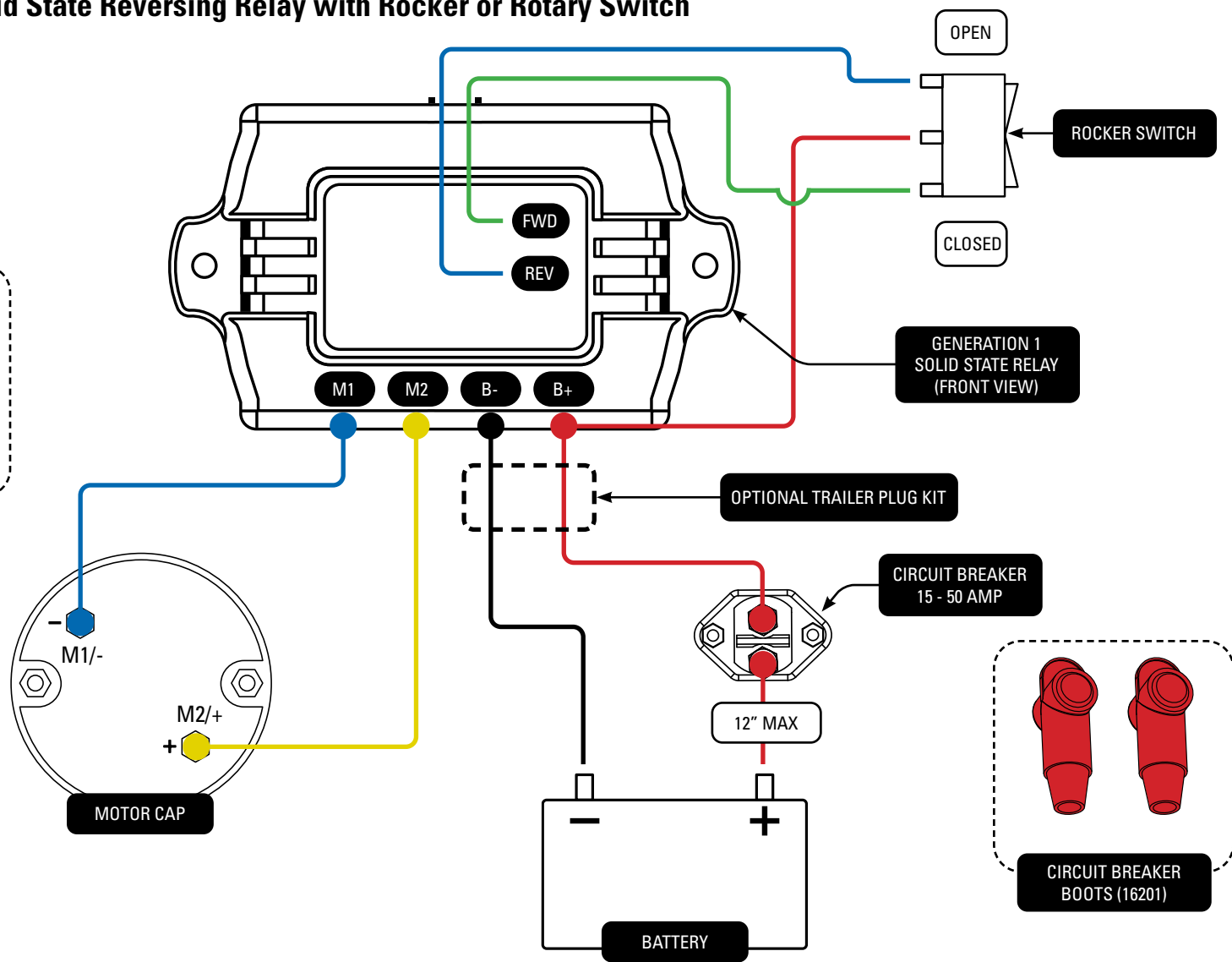



# INSTALLATION GUIDE

# Electrical Component

## Generation 1 Rite Touch® Solid State Reversing Relay with Rocker or Rotary Switch

Tarp Uncovering to Left of the Driver

- (16213) Red - Bat+
- (16206) Black - Bat - (GND)
- (16203) Yellow - M2
- (16202) Blue - M1

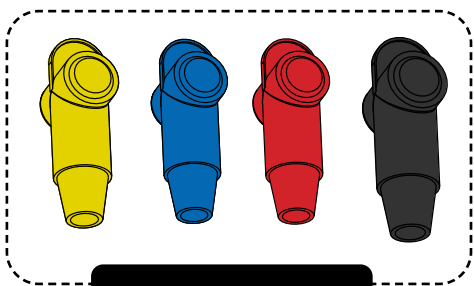

MECHANICAL RELAY BOOTS

- (16203) Yellow - M2+
- (16202) Blue - M1-

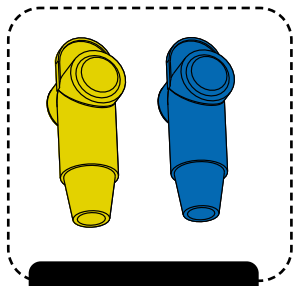

MOTOR CAP BOOTS

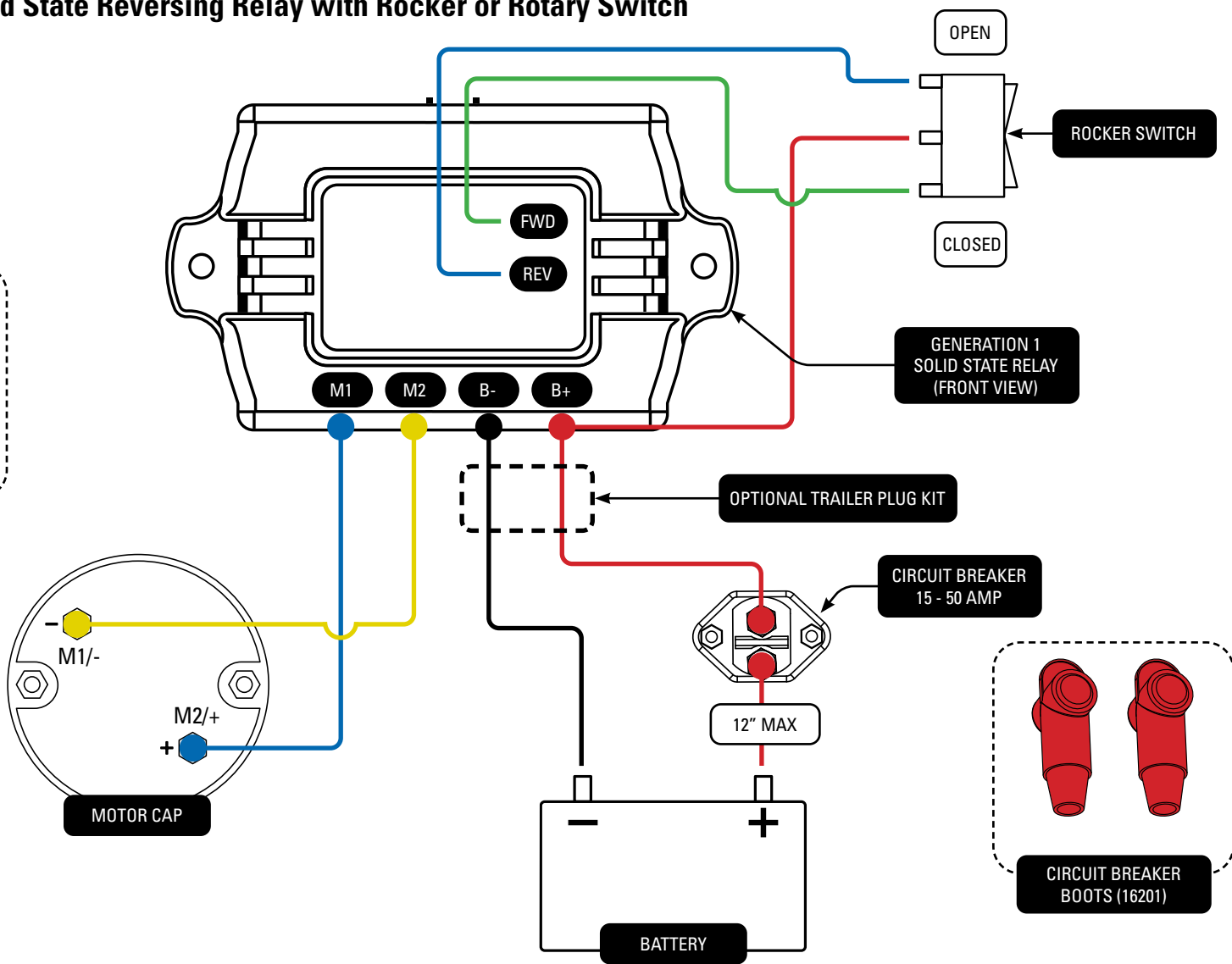



# INSTALLATION GUIDE

# Electrical Component

## Generation 1 Rite Touch® Solid State Reversing Relay with Rocker or Rotary Switch

Tarp Uncovering to the Right of Driver

- (16213) Red - Bat+
- (16206) Black - Bat - (GND)
- (16203) Yellow - M2
- (16202) Blue - M1

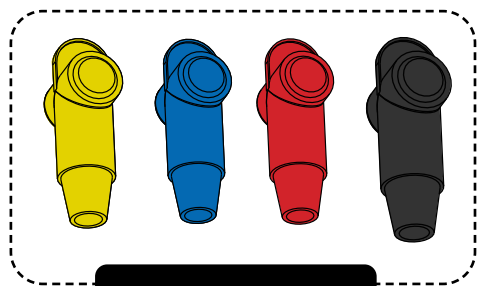

MECHANICAL RELAY BOOTS

- (16203) Yellow - M2+
- (16202) Blue - M1-

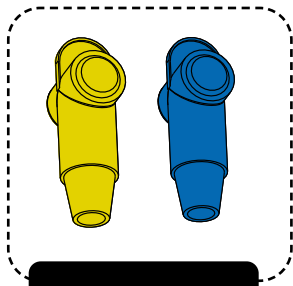

MOTOR CAP BOOTS

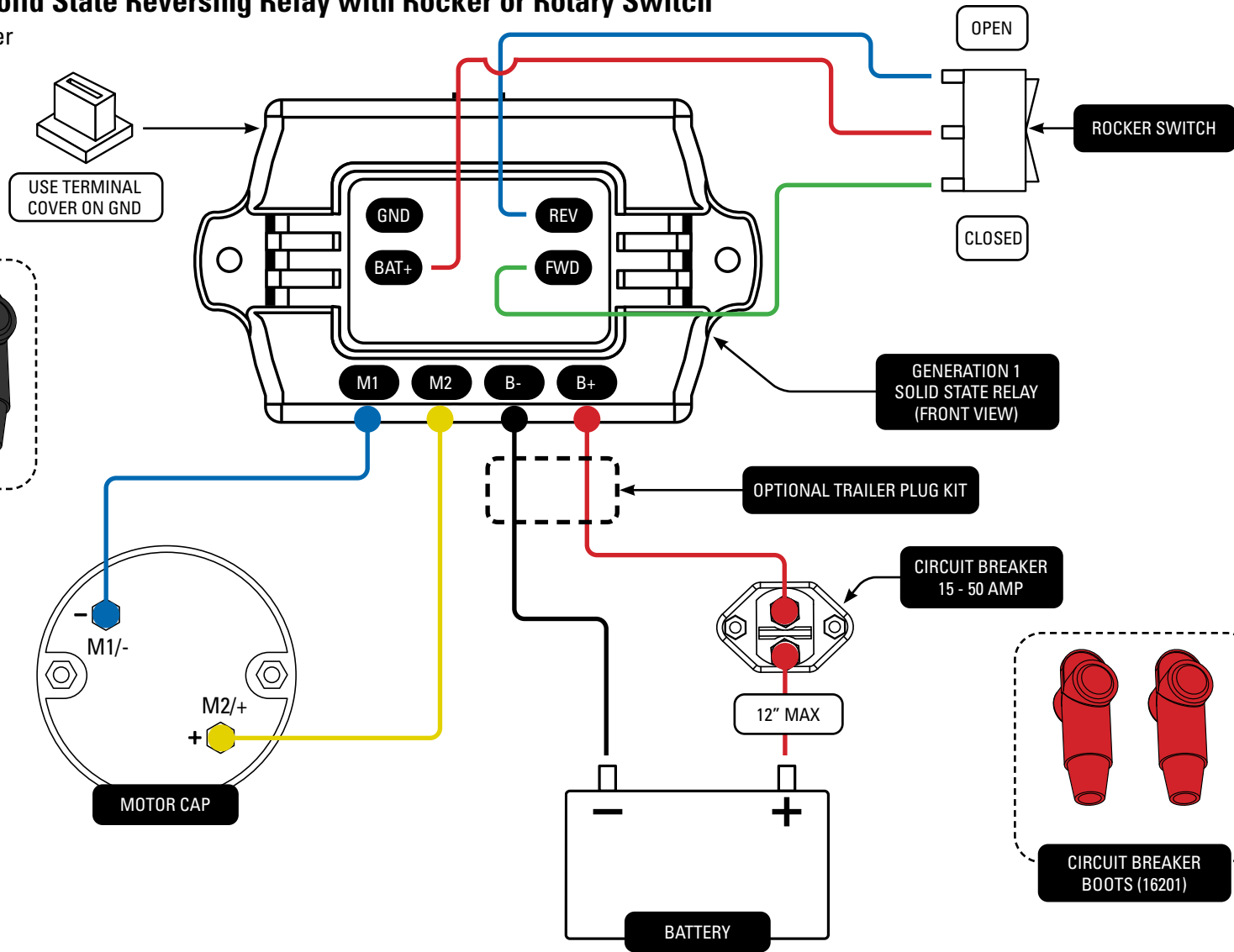



# INSTALLATION GUIDE

# Electrical Component

## Generation 1 Rite Touch® Solid State Reversing Relay with Rocker or Rotary Switch

Tarp Uncovering to the Left of the Driver

- (16213) Red - Bat+
- (16206) Black - Bat - (GND)
- (16203) Yellow - M2
- (16202) Blue - M1

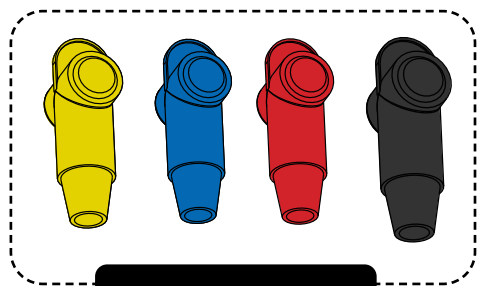

MECHANICAL RELAY BOOTS

- (16203) Yellow - M2+
- (16202) Blue - M1-

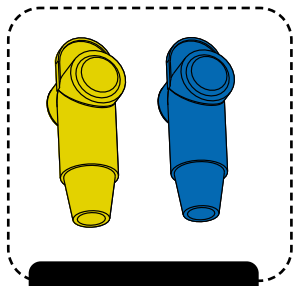

MOTOR CAP BOOTS

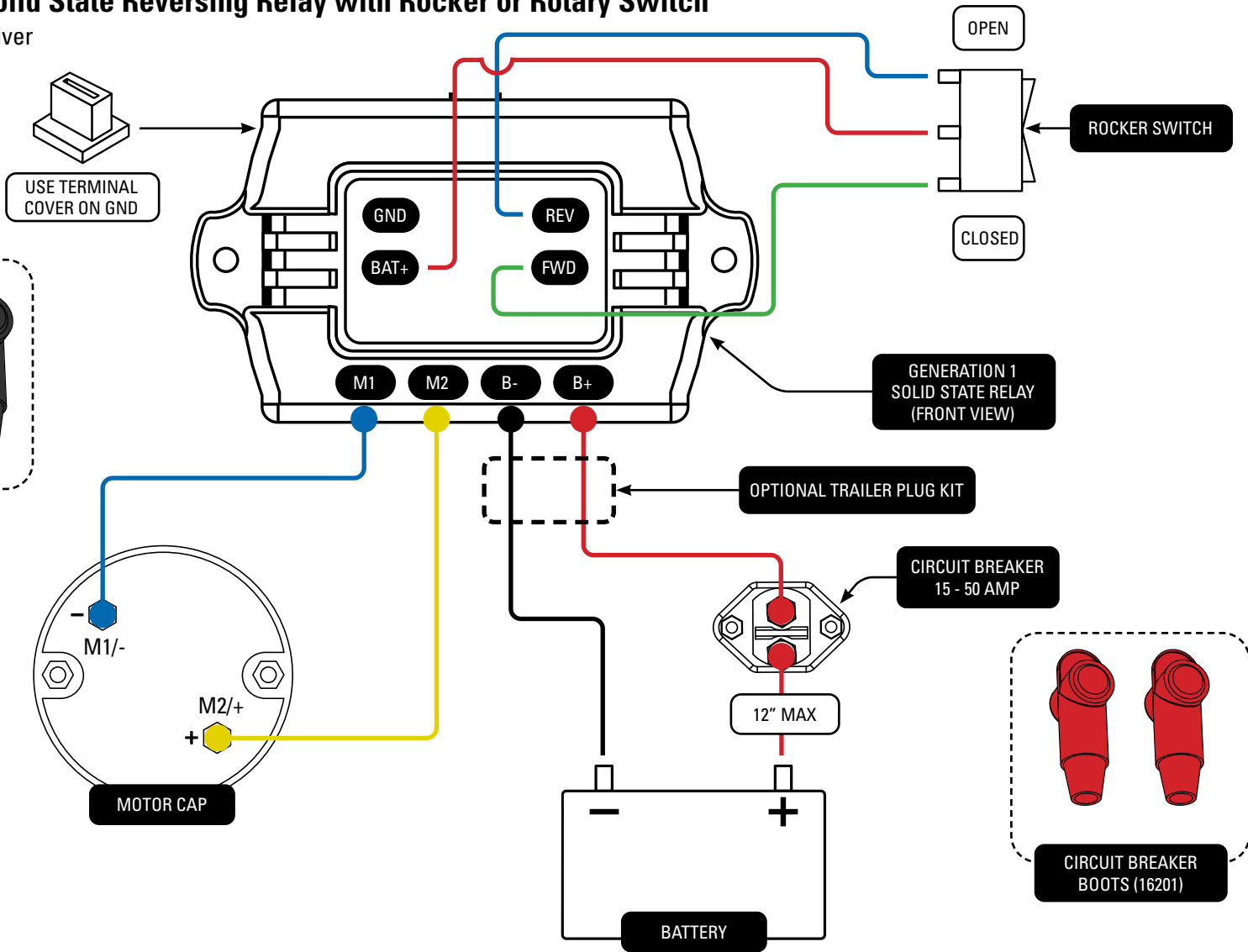



# INSTALLATION GUIDE

# Electrical Component

## Generation 1 Rite Touch® Solid State Reversing Relay with RF Switch

Tarp Uncovering to the Right of Driver

- (16213) Red - Bat+
- (16206) Black - Bat - (GND)
- (16203) Yellow - M2
- (16202) Blue - M1

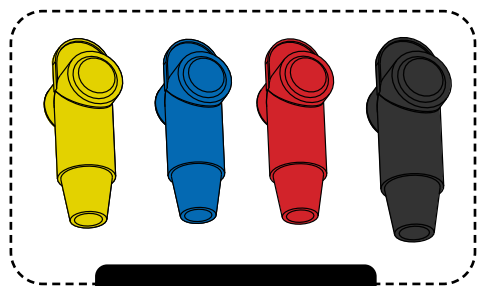

MECHANICAL RELAY BOOTS

- (16203) Yellow - M2+
- (16202) Blue - M1-

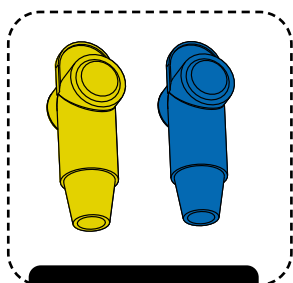

MOTOR CAP BOOTS

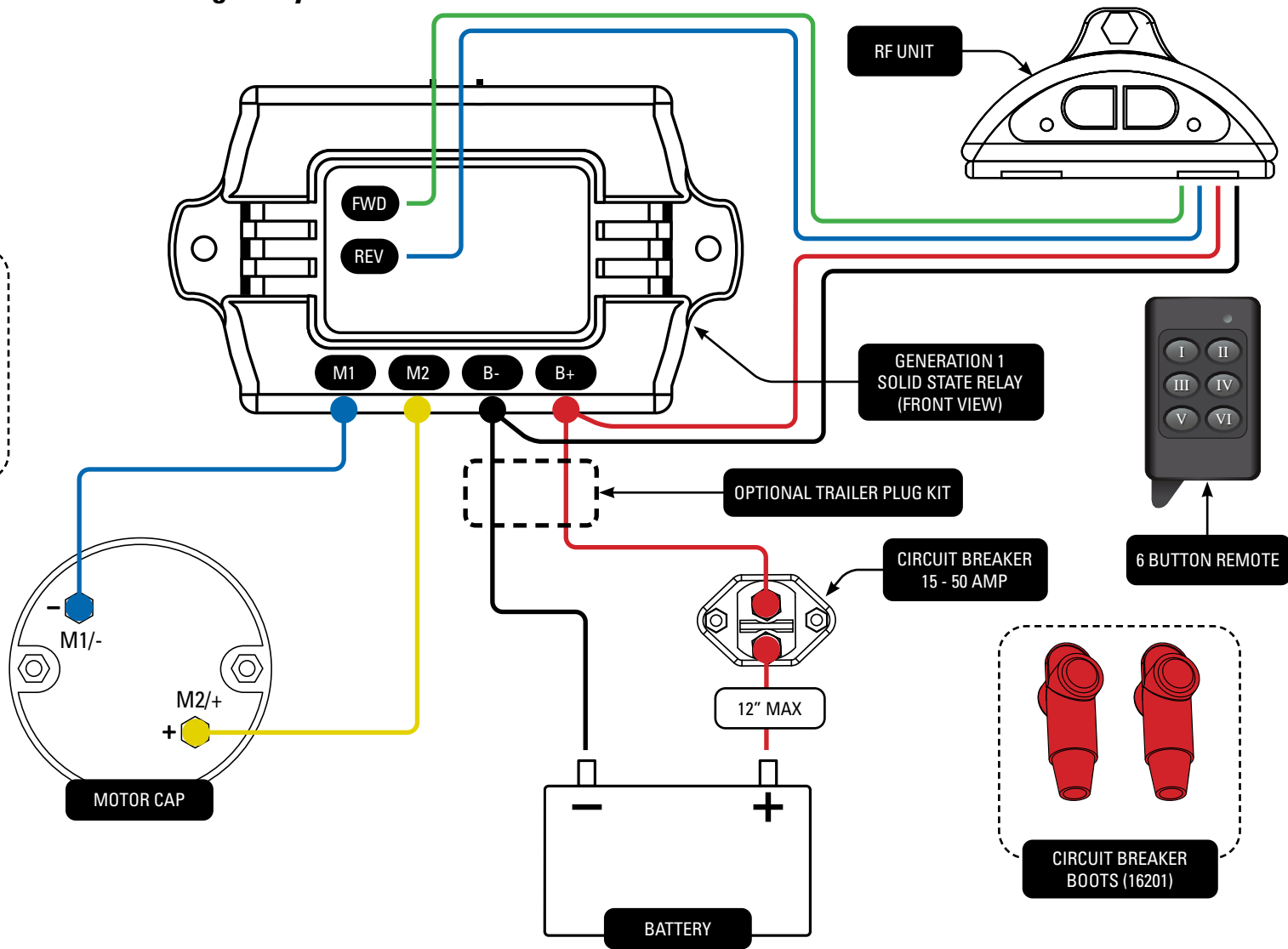



# INSTALLATION GUIDE

# Electrical Component

## Generation 1 Rite Touch® Solid State Reversing Relay with RF Switch

Tarp Uncovering to the Right of Driver

- (16213) Red - Bat+
- (16206) Black - Bat - (GND)
- (16203) Yellow - M2
- (16202) Blue - M1

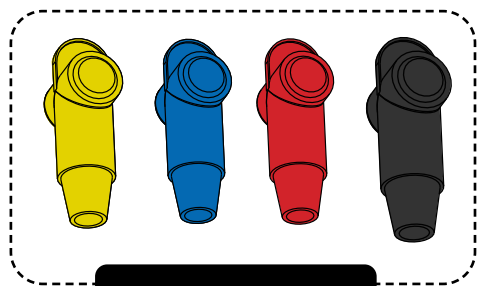

MECHANICAL RELAY BOOTS

- (16203) Yellow - M2+
- (16202) Blue - M1-

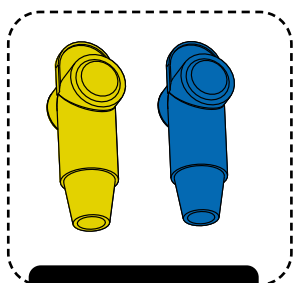

MOTOR CAP BOOTS

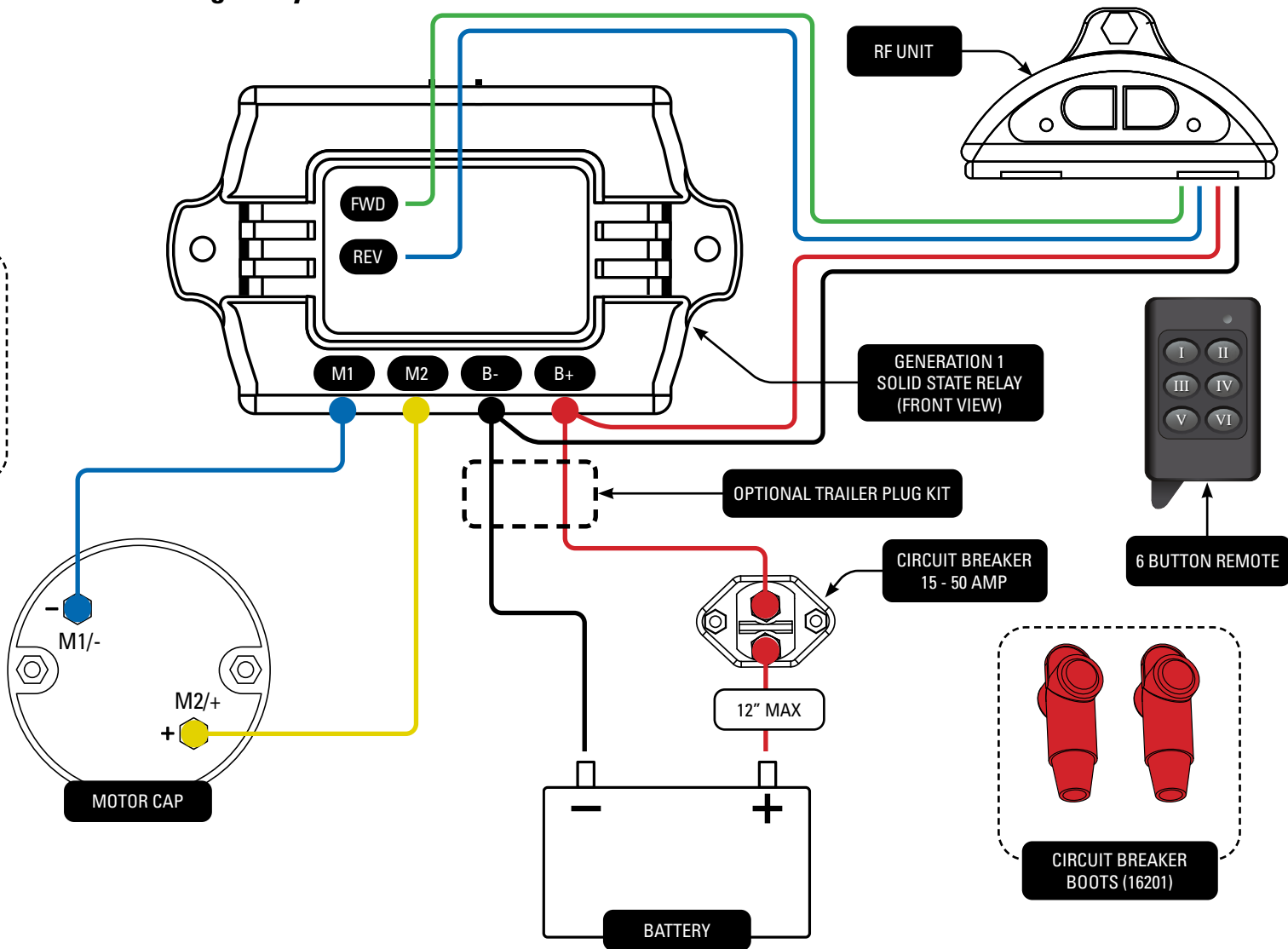



# INSTALLATION GUIDE

# Electrical Component

## Generation 1 Rite Touch® Solid State Reversing Relay with RF Switch

Tarp Uncovering to the Right of Driver

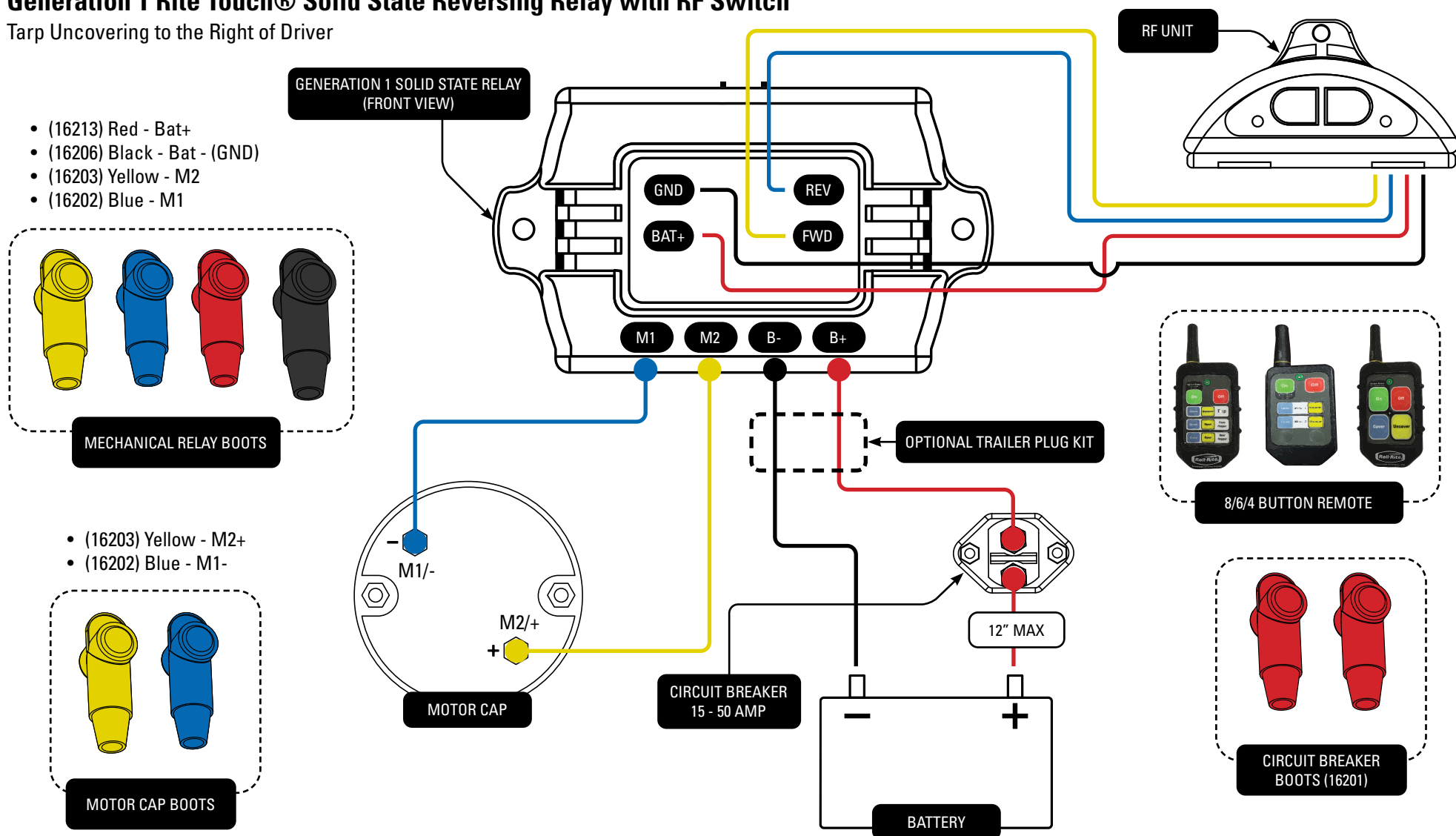



# INSTALLATION GUIDE

# Electrical Component

## Generation 1 Rite Touch® Solid State Reversing Relay with RF Switch

Tarp Uncovering to the Left of Driver

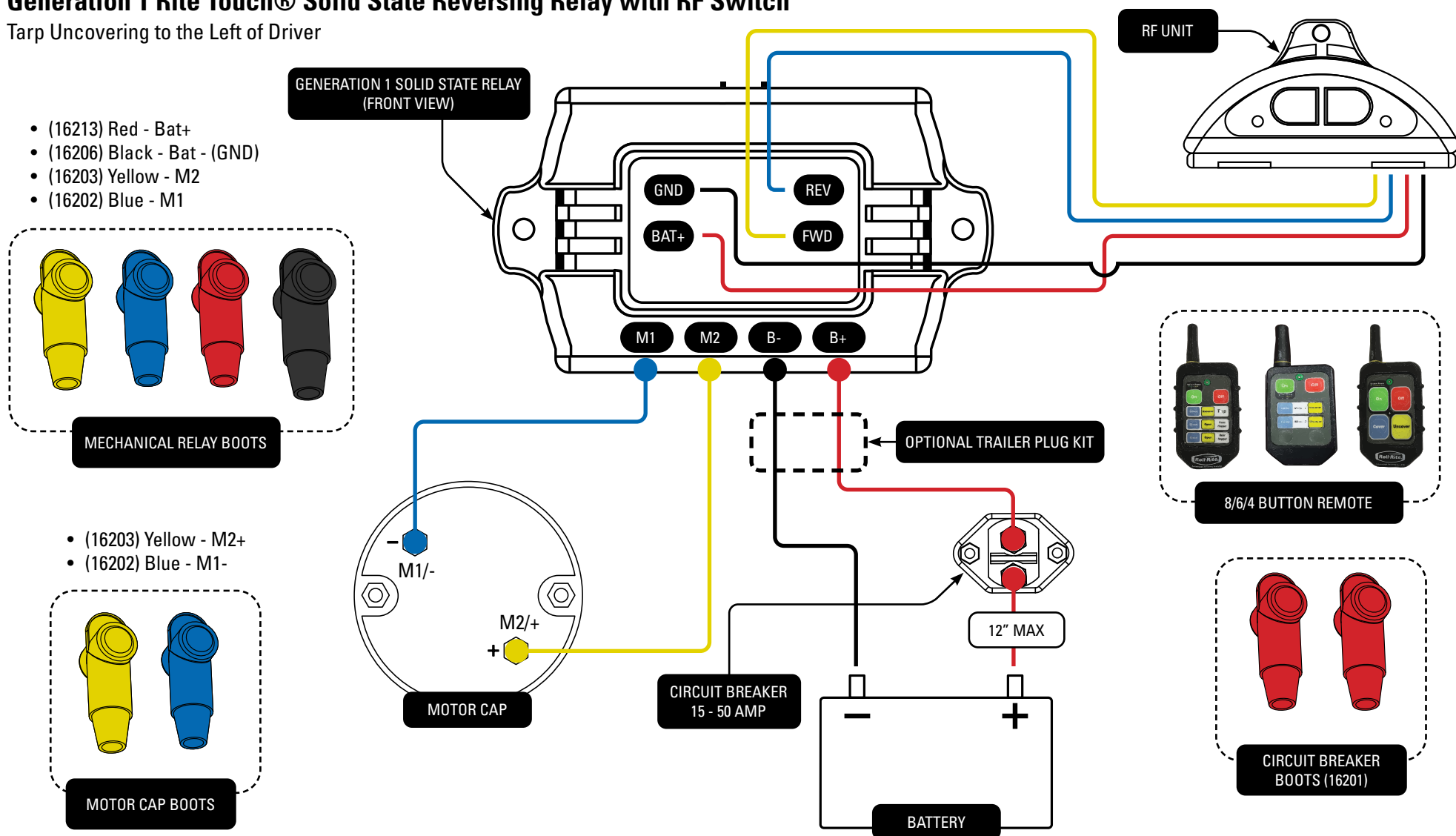



# INSTALLATION GUIDE

# Electrical Component

## Horizontal Trailer Plug Set

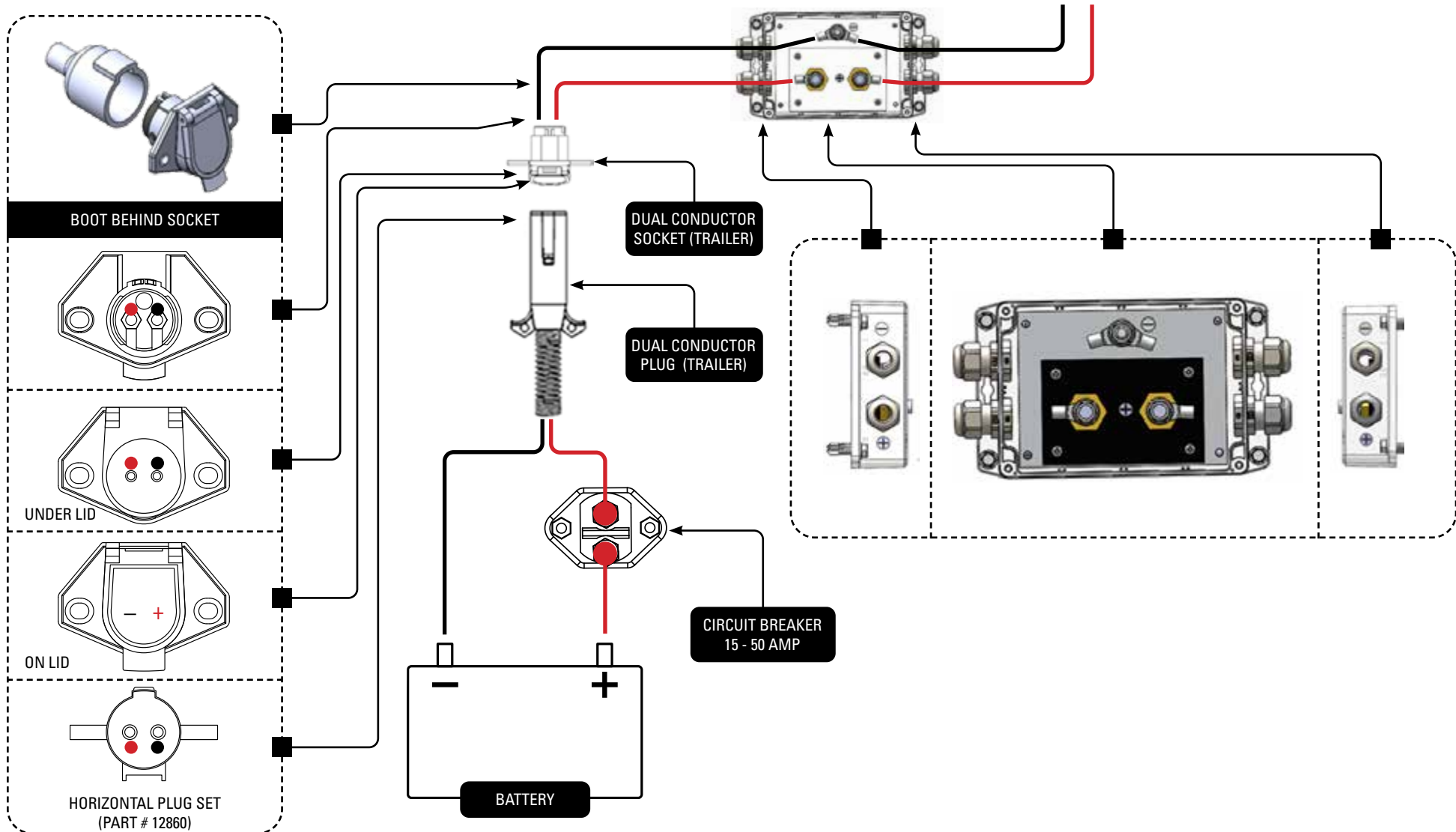



# INSTALLATION GUIDE

Electrical Component

## Vertical Trailer Plug Set

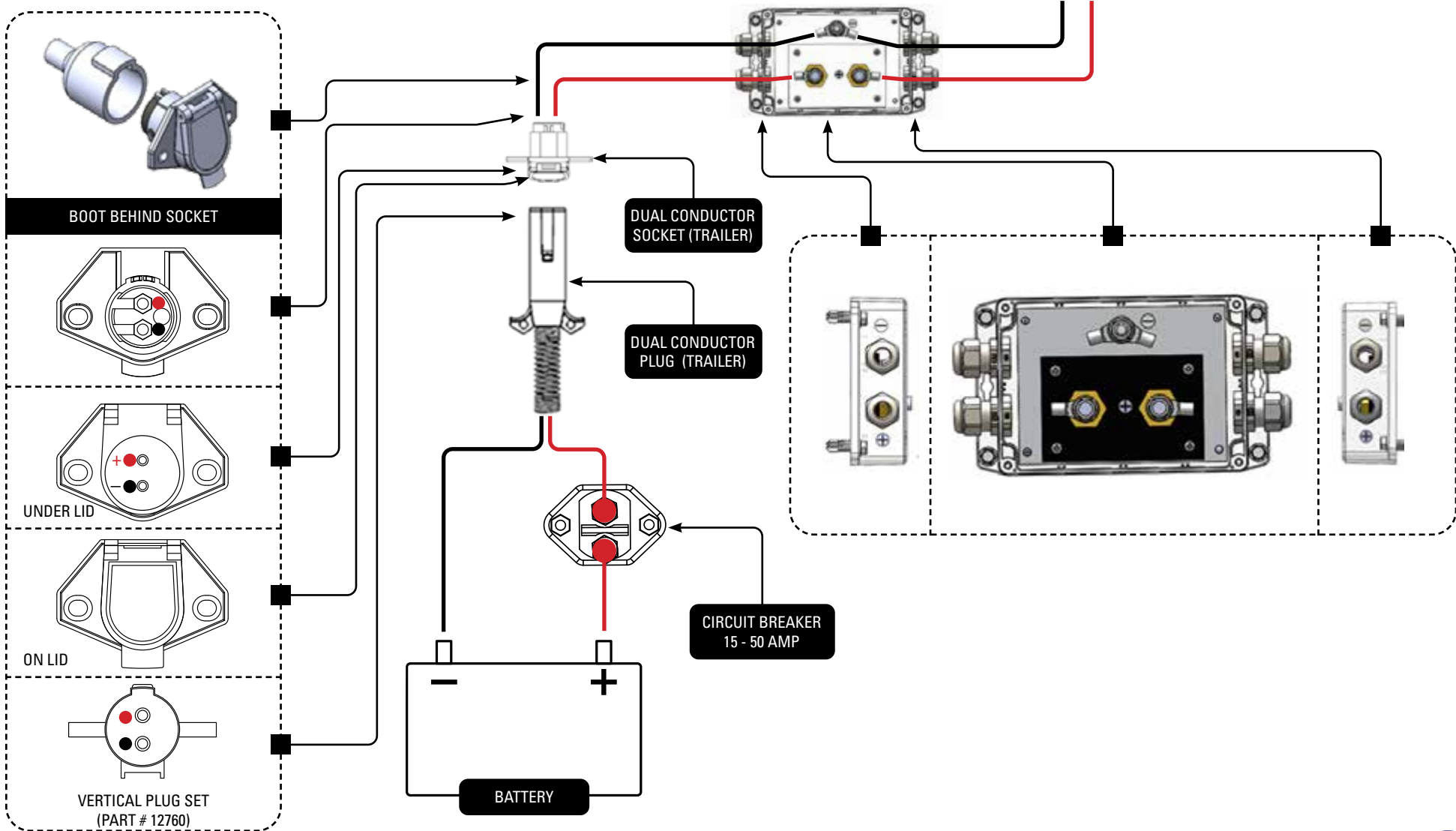



### Troubleshooting the System

Step 1: Choose one of the four system types from the four System Block Diagrams below.

1. Mechanical Relay with Rocker or Rotary Switch Block Diagram:

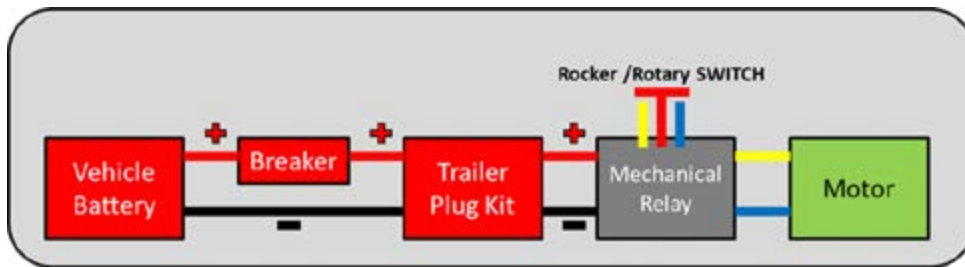

2. Mechanical Relay with RF Switch

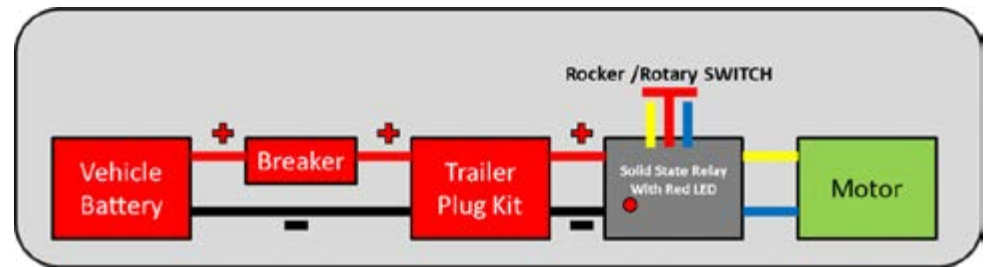

3. Solid State Relay with Rocker or Rotary Switch

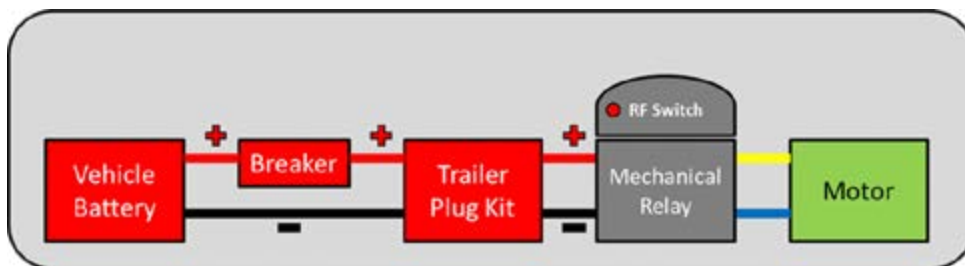

4. Solid State Relay with RF Switch

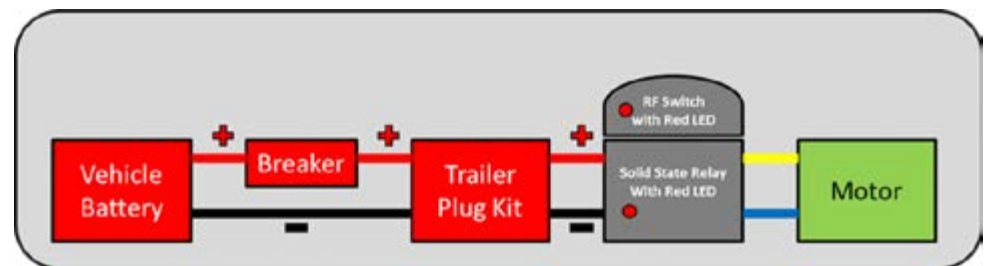



## INSTALLATION GUIDE

## Electrical Component

### Troubleshooting the System

#### Step 2: Check VOLTAGE [V] and CONTINUITY [ $\Omega$ ]

On the vehicle check all Power **+** and Ground **-** connections between vehicle battery and Motor Controller. Use the diagram as a guide, check wiring in the direction of left to right.

Check each wire for proper continuity [**Ohms  $\Omega$  < 0.2**] when disconnected.

Check the points indicated in 1 through 4 for voltage when the wires are connected.

#### 1. Mechanical Relay with Rocker or Rotary Switch Block Diagram:

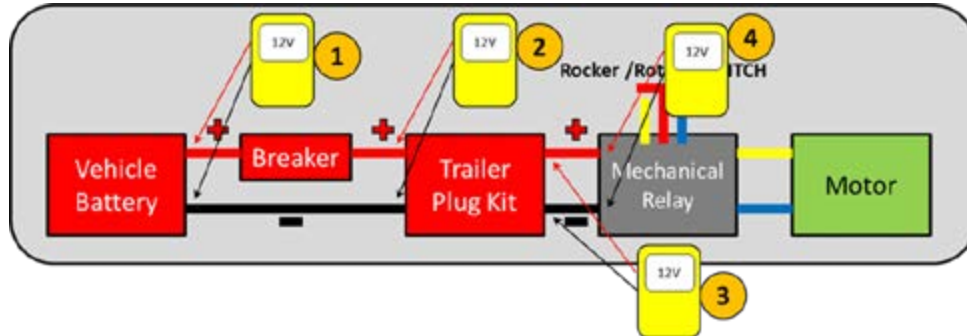

#### 2. Mechanical Relay with RF Switch

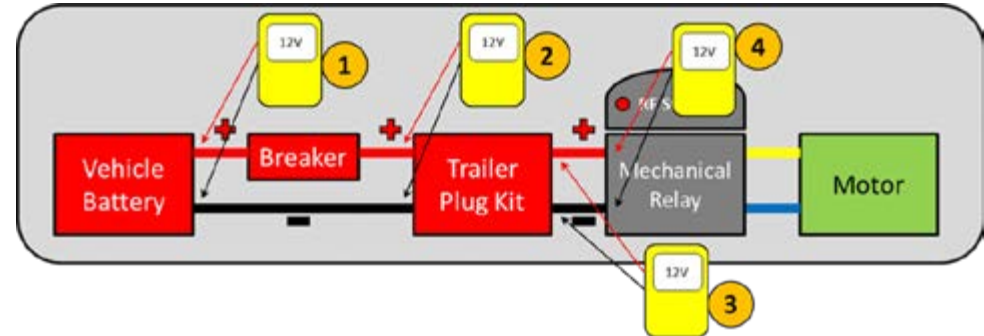

#### 3. Solid State Relay with Rocker or Rotary Switch

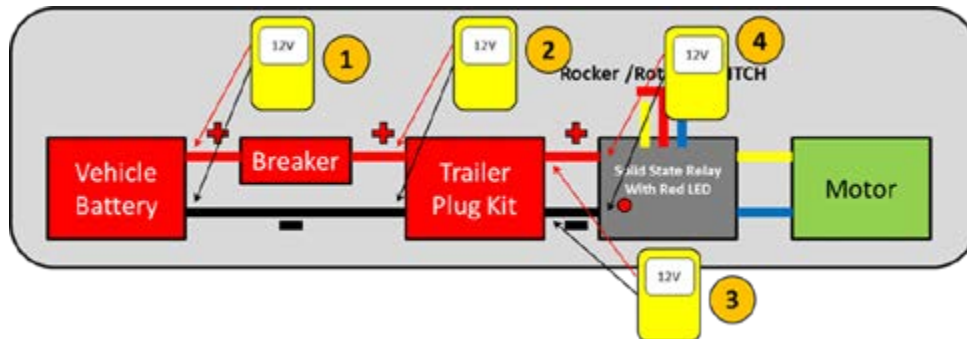

#### 4. Solid State Relay with RF Switch

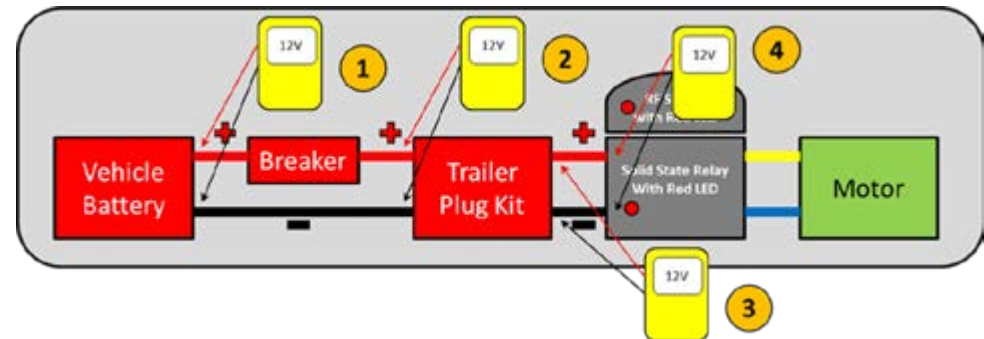

**Tip:** while moving the probe from left to right, we are checking that voltage is present through all connections. If voltage is lost at any point from 1 to 4 when moving from left to right, it should remain lost for all points to the right of the issue.



**Troubleshooting the System**

**Step 3:** Use Pin Point Tests to Isolate the Fault.

**Table 1: Mechanical Relay with Rocker Switch Pin Point Tests**

<b>Problem</b>	<b>Likely Cause</b>	<b>Action</b>
Tarp System will not Cover or Uncover	Vehicle Battery Low	Charge Vehicle Battery -or- Start Engine to operate Alternator
Tarp System will not Cover or Uncover	System Breaker is open due to short circuit in system -or- System breaker is open due to motor stall condition for several seconds	Close Breaker and operate the system. If breaker continues to open: (1) Check all positive wires in system are not shorted to the truck or trailer chassis (2) Check that all positive wire terminal connections to the right of the breaker are not shorted to the truck or trailer chassis (3) Check that neither yellow nor blue motor wires are not shorted to truck or trailer chassis (4) Disconnect the battery and ground from the motor controller. Check the continuity [Ω] between and BAT+ terminal of motor controller and GND terminal of the motor controller. If this value of resistance is less than kΩ replace the Motor Controller. (5) Disconnect the motor terminals. Check the continuity [Ω] between the M1 motor terminal and the motor cap stud. If the value is less than 1 kΩ replace the motor. Complete the same test between M2 and the motor cap stud.
Tarp System will not Cover or Uncover	Motor Relay Rocker or Rotary Switch Failure	Check the rocker or rotary switch continuity [Ω]. (1) Check continuity between switch Red Power Terminal and Green Open output. The value should be OL when the switch is open and less than 0.5 Ω when the switch is closed. (2) Complete the same test between the Red Power Terminal and the Blue Close output. The value should be OL when the switch is open and less than 0.5 Ω when the switch is closed. If any test fails, replace the switch.
Tarp System will not Cover or Uncover	Motor Relay Rocker or Rotary Switch Harness Failure	Check the rocker or rotary switch harness continuity [Ω]. (1) Check continuity Ω of each of the three wires (1) Red, (2) Green, and (3) Blue. Resistance values should be less than 0.2 Ω. If any wire is found to have high resistance, replace the harness. (2) Plug the harness Red, Blue and Green wires into the known good switch. (3) Connect the Positive terminal to a 12V source. (4) Connect a volt meter between the 12V source ground and the end of the green harness. (5) Press the Open switch. The voltmeter should read 12V. If it does not, replace the harness. (6) Repeat steps 3, 4, and 5 on the blue wire, using the Close option on the switch.



**Troubleshooting the System**

**Step 3: Use Pin Point Tests to Isolate the Fault**

**Table 2A: Solid State Relay with Rocker Switch Pin Point Tests with LED Flash Code Table**

LED Activity	Status of System	LED Activity Duration
Off	Ready to Run	While at rest
Solid On	Motor is running normally	While running
2 Flashes	Programmed stall current achieved	Repeats twice then resets
3 Flashes	Module over current protection	Repeats for 10 seconds then resets
4 Flashes	Module overheat protection	Repeats for 10 seconds then resets
5 Flashes	Over Voltage (> 15.5v)	Will repeat continuously until voltage drops below 15.5v then reset after 10 sec. During 10 sec reset unit will function
6 Flashes	Under Voltage (< 7.5v)	Will repeat continuously until voltage is above 7.5v then reset after 10 sec. During 10 sec reset the unit will function
7 Flashes	Wiring Fault: Motor Circuit is Shorted	Will continue to repeat until fault is corrected the rest.

**Table 2B: Solid State Relay with Rocker Switch Pin Point Tests with LED Flash Code Table**

Problem	Likely Cause	Action
Tarp System will not Cover or Uncover	Vehicle Battery Low	Charge Vehicle Battery -or- Start Engine to operate Alternator
Tarp System will not Cover or Uncover with Solid State Relay Flash 2 times	Current Limit of System Achieved	Mechanical binding, blocking, or motor brake is preventing the motor from rotating. Check for item in path of system prevent movement of a machine element. Remove motor brake cap and check for debris in motor brake.
Tarp System will not Cover or Uncover with Solid State Relay Flash 3 times	Over current condition observed by Solid State Relay	Check for short condition in motor or motor supply harness
Tarp System will not Cover or Uncover with Solid State Relay Flash 4 times	Over temperature condition observed by Solid State Relay.	Allow system to cool for 30 minutes before further use. If issue persists after 30 minute cool down, replace Solid State Relay.



**Troubleshooting the System**

**Table 2B: Solid State Relay with Rocker Switch Pin Point Tests with LED Flash Code Table (Continued)**

<b>Problem</b>	<b>Likely Cause</b>	<b>Action</b>
Tarp System will not Cover or Uncover with Solid State Relay Flash 5 times	Over Voltage (V > 15.5) observed by Solid State Relay	(1) Check vehicle battery voltage. It should be less than 14.4V steady state while engine is running and alternator is operating. If it is greater than 14.4V steady state, check alternator voltage regulator on vehicle. (2) Check for excessive load dump condition between vehicle chassis, vehicle battery and input to motor controller. Does the 5 flash occur at the moment another chassis load is turned off? (3) If vehicle electrical system is found to have normal operating voltage during operation (11.8 < V < 14.4), and problem persists, replace the Solid State Motor controller
Tarp System will not Cover or Uncover with Solid State Relay Flash 6 times	Under Voltage (V < 7.5V) observed by Solid State Relay	(1) Disconnect vehicle batteries from chassis then wait 30 minutes. After 30 minutes rest with no loads present each battery should be greater than 12.2V. If the voltage is less than 12.2V run a battery load test to determine battery state of health. Solid State motor controller operation is inconsistent when chassis batteries are less than 50% state of charge. (2) Check for current limiting condition between chassis batteries and Solid State Motor controller. An intermittent open circuit or high resistance connection may exist in the wiring, allowing a continuity test to pass, but limiting current during loading. (3) If vehicle electrical system is found to have normal operating voltage during operation (11.8 < V < 14.4), and problem persists, replace the Solid State Motor controller
Tarp System will not Cover or Uncover with Solid State Relay Flash 7 times	Short Circuit in the Motor or Motor Circuit.	(1) Check the Motor for a short first. Disconnect the motor terminals. Check the continuity [Ω] between the M1 motor terminal and the motor cap stud. Complete the same test between M2 and the motor cap stud. If the value is less than 1 kΩ replace the motor. (2) Check for a short circuit between Yellow Motor Lead and Chassis. (3) Check for a short circuit between the Blue Motor Lead and Chassis. (4) if the motor and motor supply wiring are found to be OK, replace the Solid State relay.
Tarp System will not Cover or Uncover	Motor Relay Rocker or Rotary Switch Failure	Check the rocker or rotary switch continuity [Ω]. (1) Check continuity between switch Red Power Terminal and Green Open output. The value should be OL when the switch is open and less than 0.5 Ω when the switch is closed. (2) Complete the same test between the Red Power Terminal and the Blue Close output. The value should be OL when the switch is open and less than 0.5 Ω when the switch is closed. If any test fails, replace the switch.
Tarp System will not Cover or Uncover	Motor Relay Rocker or Rotary Switch Harness Failure	Check the rocker or rotary switch harness continuity [Ω]. (1) Check continuity Ω of each of the three wires (1) Red, (2) Green, and (3) Blue. Resistance values should be less than 0.2 Ω. If any wire is found to have high resistance, replace the harness. (2) Plug the harness Red, Blue and Green wires into a known good switch (3) Connect the Positive terminal to a 12V source. (4) Connect a volt meter between the 12V source ground and the end of the green harness. (5) Press the Open switch. The voltmeter should read 12V. If it does not replace the harness. (6) Repeat steps 3, 4, and 5 on the blue wire, using the Close option on the switch.



Troubleshooting the System

Table 3: Troubleshooting the RF System Receiver

Problem	Possible Cause	Solution
System does not operate from Receiver switches	Truck Battery is low	Turn off all vehicle accessories and running lights. Wait 10 minutes. Check the vehicle battery voltage. If vehicle battery voltage is less than 12.2 Volts, service the vehicle batteries.
System does not operate from Receiver switches	Truck - to - Trailer harness or plug issue	With trailer plug inserted, using a multi-meter, check the Voltage between the BAT+ and GND terminals of the Motor Relay. It should be greater than 12V. Compare this value to battery voltage. If the motor relay input voltage is more than 2V lower than the battery voltage, isolate the problem to one or more components in the Truck to Trailer circuit and replace that circuit component.
System does not operate from Receiver switches	Motor Relay internal fault	With trailer plug inserted, using a multi-meter, check the Voltage between the BAT+ and GND terminals of the Motor Relay. This value should be greater than 12V. Next, check the voltage between the RF power Spade Terminals BAT+ and GND. The value at the RF power terminals should be the same as the value of the BAT+ and GND. If they are not, replace the Motor Relay.
System does not operate from Receiver switches	After running the first three tests presented in this table, the possible cause is the RF Receiver	Check all Power and Ground connections between vehicle battery and RF Receiver. Check motor relay operation Assure the device is being powered up properly – see Page 4 of the Roll Rite RF System Quick Start Guide. If all are found to be OK, replace the RF Receiver



Troubleshooting the System

Table 4: Troubleshooting the RF Transmitter

Problem	Possible Cause	Solution
System operates from receiver switches but does not operate from transmitter	Transmitter is not in operational mode	Turn the transmitter on – see Page 6 of the Roll Rite RF System Quick Start Guide
System operates from the Transmitter intermittently	Transmitter Battery is low	Change Transmitter Battery – see Page 22 of the Roll Rite RF System Quick Start Guide
System operates from the Transmitter intermittently	Transmitter turned OFF while in use	Do not turn the transmitter off while running the system
Transmitter does not power up	Transmitter Battery	Change Transmitter Battery – see Page 22 of the Roll Rite RF System Quick Start Guide
Transmitter does not power up	Receiver is in Lock Out Mode	Turn receiver on to Operating mode – see Page 4 of the Roll Rite RF System Quick Start Guide
Transmitter does not power up	Transmitter is not paired	Pair transmitter to receiver. Follow directions starting on Page 8 through Page 21 of the Roll Rite RF System Quick Start Guide
Transmitter does not power up	Transmitter internal fault	After checking the first three potential reasons described previously in this table, replace the transmitter