

ATTENTION

DURING INSTALLATION, SOME FABRICATION MAY BE REQUIRED.

Part #: 109895
Revised: 02/17/26 - WLH



CAUTION

The Motor Reversing Relay manages switched battery energy. Failure to install in accordance with the requirements in this document may result in unintended release of battery energy storage, bodily injury, and property damage.

Installation and Preventative Maintenance Requirements

- The Motor Reversing Relay shall be installed on a vertical plane with the wires from terminals (B+, B-, M2, M1) facing down as shown in Figure One. NOTE: This is the only approved installation orientation for the Motor Reversing Relay.
 - Two surface mounting locations are provided on the Motor Reversing Relay. Both locations shall be utilized in the installation using 1/4" – 20 x 1" fasteners (P/N 18700) torque to 8 ft-lbs (11 Nm)
 - All terminals shall be coated with dielectric grease prior to installation.
 - Insulated Terminal Boots shall be installed on all High Current Terminals (B+, B-, M2, and M1) in accordance with Installation Instructions. See Wiring Diagram, Note A.
 - Route all electrical wires from the Motor Reversing Relay in a manner that will avoid wire insulation chafing, pinching, and wear from other items on the truck chassis or wear from the environment.
 - The Roll Rite 35A Circuit Breaker shall be installed in accordance with the Installation Requirements and the Wiring Diagram reference.
 - » The mounting surface shall be chosen to prevent contact between terminals and chassis components. A Minimum clearance of 2 inches (50 mm) between the Circuit Breaker terminals and any surface or object. See Wiring Diagram, Note A
 - » Insulated Boots must be installed on Circuit Breaker terminal connections. See Wiring Diagram, Note A
 - » Circuit Breaker shall be installed in the orientation shown in Figure Two.
- NOTE: This is the only approved installation orientation for the Circuit Breaker**
- Inspect the terminals of the Motor Reversing Relay every six months.
 - » Remove the Insulated Terminal Boots, inspect and replace if damaged
 - » Remove and clean all electrical current carrying connections.
 - » Reapply dielectric grease and reinstall in accordance with the Installation Instructions



- Wiring Requirements:
 - » Switch Harness
 - Maximum Wire Gage 14 AWG. Minimum Wire Gage 16 AWG.
 - Use Insulated Wire Terminals for S1, S2, and Switch Power, Forward and Reverse
 - Use Insulated Ring Terminal (P/N 16080) for Switch Power connection to B+
 - Properly sized crimping tool (14/16 AWG) shall be used to connect wires to 10915 and 16080 terminals
 - Terminals shall be installed 14/16 AWG such that no current carrying strands are exposed after crimp has been applied
 - Heat shrink or appropriate insulated tape shall be used to seal terminals to wire 14/16 AWG wire insulation
 - Switch Harness minimum dielectric strength between leads shall be no less than 0.833 k Ω with switch installed
 - Maximum voltage drop across crimped terminals shall be less than 7mV at 14 VDC/35A
 - » Motor Wiring Harness
 - Minimum 8 AWG Two Conductor Wire and maximum 4 AWG Two Conductor Wire shall be used.
 - Terminals shall be installed on 4-8 AWG wire such that no current carrying strands are exposed after crimp has been applied
 - Properly sized crimping tool (4-8 AWG) shall be used to connect wires to terminals
 - Heat shrink or appropriate insulated tape shall be used to seal terminals to 4-8 AWG wire insulation
 - Minimum dielectric strength of motor harness shall be no less than 0.833 k Ω
 - Maximum voltage drop across crimp shall be less than 4mV at 14VDC/100A
 - » Power Wiring Harness
 - Minimum 8 AWG Two Conductor Wire and Maximum 4 AWG Two Conductor Wire shall be used.
 - Terminals shall be installed on 4-8 AWG wire such that no current carrying strands are exposed after crimp has been applied
 - Properly sized crimping tool (4-8 AWG) shall be used to connect wires to terminals
 - Heat shrink or appropriate insulated tape shall be used to seal terminals to 4-8 AWG wire insulation
 - Minimum dielectric strength of motor harness shall be no less than 0.833 k Ω
 - Maximum voltage drop across crimp shall be less than 4mV at 14VDC/100A
 - » Keep this document for future reference.



Fig. 1 Installation Orientation of the Motor Reversing Relay.

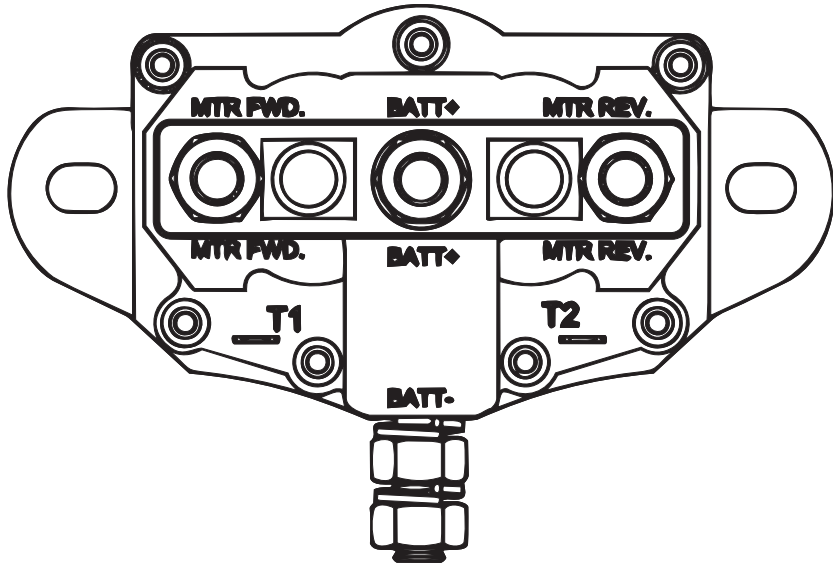
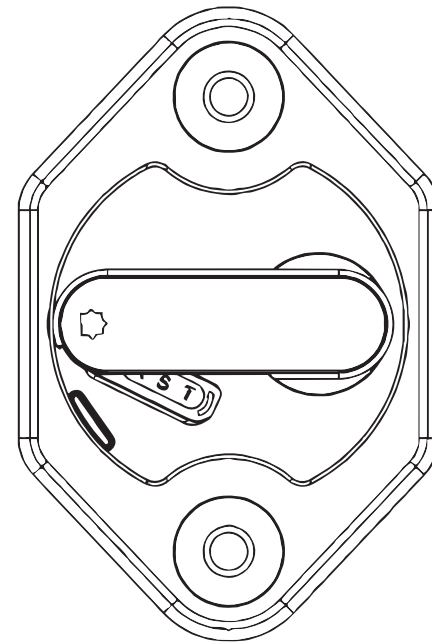

Fig. 2 Installation Orientation of the Roll Rite 35A Circuit Breaker (P/N 17918).





INSTALLATION MANUAL

Motor Reversing Relay

Wiring Diagram

(for Reference Only, Follow Installation Instructions for Required Procedure)

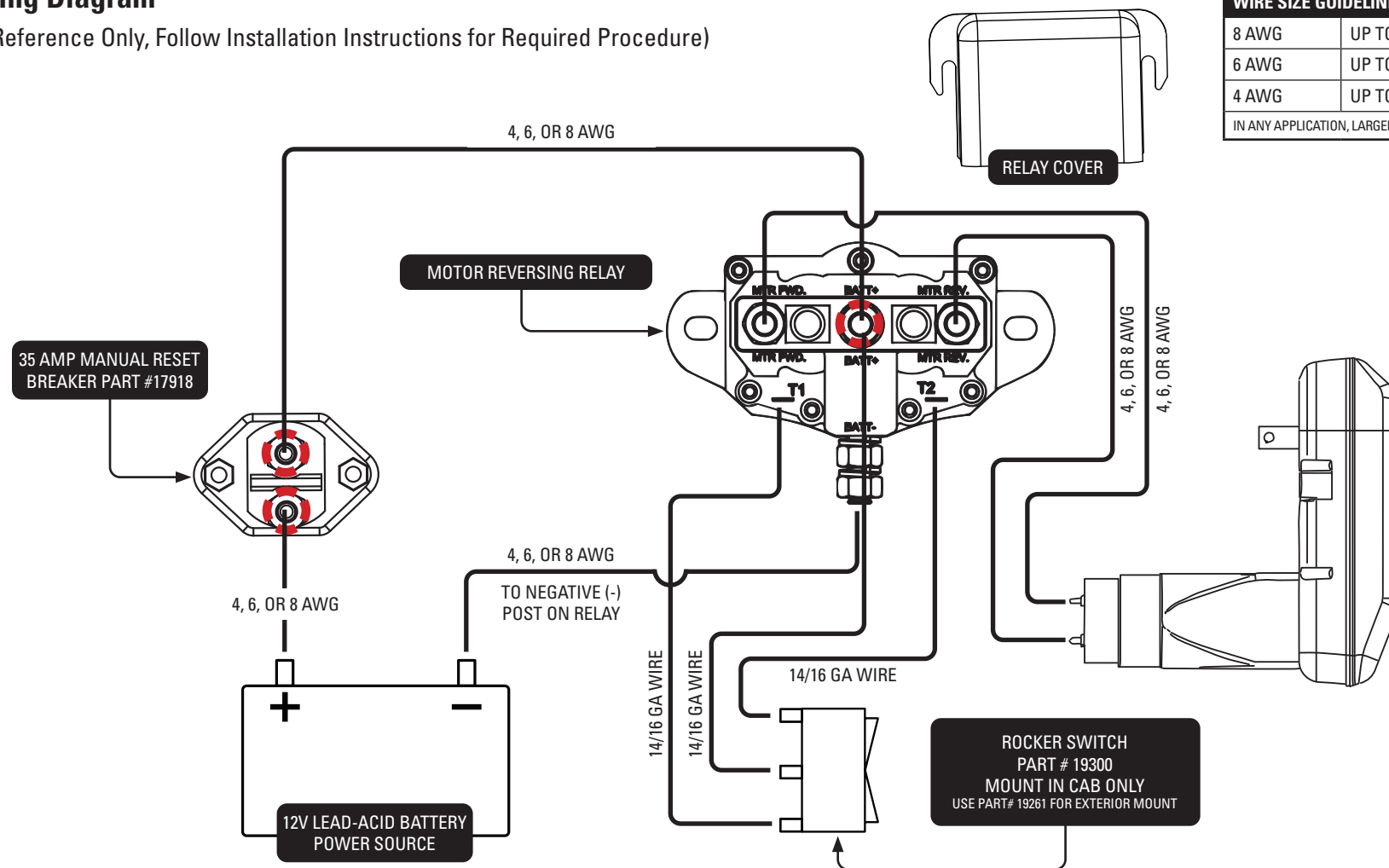

WIRE SIZE GUIDELINE	
8 AWG	UP TO 40'
6 AWG	UP TO 85'
4 AWG	UP TO 135'
IN ANY APPLICATION, LARGER WIRE = BETTER MOTOR PERFORMANCE	

Note A: As Installed, The terminals indicated with  (dash circle outline) contain un-switched 12V energy at all times. Installation Requirements must be followed to avoid contact between these terminals and chassis ground.



Installation Instructions:

1. Prior to installation of the Motor Reversing Relay:
 - a. Install the Roll Rite Automated covering system, including the Electric Gear Motor
 - b. Install and Route the Electric Gear Motor Supply Wire (4 or 6 gage, two conductor wire) to the pre-determined Motor Reversing Relay Installation Location, consistent with the Installation Requirements
 - c. Install the Rocker Switch and route the rocker switch harness (14 or 16 gage, three conductor harness) to the pre-determined Motor Reversing Relay Installation Location, consistent with the Installation Requirements
2. Install the Electrical Connections to the Relay:
 - a. Gear Motor Connection
 - i. Place Insulated Terminal Boots on the Electric Gear Motor Supply Harness over the ring terminal connections for FWD and REV that will be attached to the Motor Reversing Relay
 - ii. Apply dielectric grease to the FWD and REV Ring Terminals on the Electric Gear Motor Supply Harness
 - iii. Apply dielectric grease to the Motor Reversing Relay Terminals, FWD and REV
 - iv. Connect the Electric Gear Motor Supply Harness to the Terminals, FWD and REV
 - v. Apply torque to the FWD and REV terminal studs. Do not exceed 35 in-lbs (4Nm)
 - vi. Slide the Insulated Terminal Boot over the electrical connection, fully covering the terminal connection
 - b. Rocker Switch Connection
 - i. Apply dielectric grease to the Motor Reversing Relay Spade Terminal FWD and REV
 - ii. Apply dielectric grease to the Connector Terminals of the Rocker Switch Harness
 - iii. Place the Rocker Terminal Switch Harness Flag / Spade Receiver Connectors on the Motor Reversing Relay Spade Terminals T1 and T2



NOTE: Prior to Completing next step, assure the chassis power and ground are not connected to the lead acid battery. Failure to follow this direction may result in arc current.



- c. Chassis Ground Connection (GND)
 - i. Place Insulated Terminal Boot on the Power Supply Harness Ground Wire Ring terminal that will be attached to the Motor Reversing Relay
 - ii. Apply dielectric grease to the Power Supply Harness Ground Wire Ring Terminal
 - iii. Apply dielectric grease to the Motor Reversing Relay GND Terminal
 - iv. Connect the Power Supply Harness Ground Wire to the GND Terminal on the Motor Reversing Relay
 - v. Apply torque to the GND terminal stud. Do not exceed 15 ft-lb (20 Nm)
 - vi. Slide the Insulated Boot over the electrical connection, fully covering the terminal connection
 - d. Chassis Power Connection (+BAT)
 - i. Place Insulated Terminal Boot on the Power Supply Harness Battery Wire Ring terminal that will be attached to the Motor Reversing Relay
 - ii. Apply dielectric grease to the Power Supply Harness Battery Wire Ring Terminal
 - iii. Apply dielectric grease to the Motor Reversing Relay +BAT Terminal
 - iv. Connect the Power Supply Harness Battery Wire to the +BAT Terminal on the Motor Reversing Relay
 - v. Apply torque to the +BAT terminal stud. Do not exceed 35 in-lbs (4Nm)
 - vi. Slide the Insulated Terminal Boot over the electrical connection, fully covering the terminal connection
3. Install the Motor Reversing Relay on the Chassis Mounting location
- a. Assure the mounting location meets the Installation and Preventative Maintenance Requirements in this document
 - b. Install the 1/4"-20 x 1 fasteners to two mounting locations of the Motor Reversing Relay. Torque hand tight not to exceed 8 ft-lb (11 Nm)
4. Check for Power Short Condition:
- a. Using a multi-meter on the Resistance Measurement Setting (Ω), measure resistance between Chassis Power (+BAT) wire end and a clean ground location on the chassis.
 - b. Record the measured value of Resistance (Ω)
 - c. If the value is less than 8.33 k Ω , discontinue installation
 - d. Determine location of short between power harness and chassis ground prior to continuing installation
5. Install Relay Cover



Note: Failure to follow Installation Requirements may result in bodily injury and property damage.



5. Install the 35A Manual Reset Circuit Breaker
 - a. The 35A Manual Reset Circuit Breaker is a surface mount device. Mount such that face of Circuit Breaker and reset switch are easily accessible.
 - b. Choose a location to mount the 35A Circuit Breaker which ensures at least 2" clearance between the terminals and any other surface.
 - c. Coat the Circuit Breaker terminals with dielectric grease
 - d. Coat the Positive Wire Ring terminal with dielectric grease
 - e. Install the Insulated Terminal Boot on the Motor Reversing Relay Power Harness Positive Wire Ring Terminal. Note: the opposite end is connected to the relay, mounted on chassis.
 - f. Install the Motor Reversing Relay Power Harness Positive Wire Ring Terminal to the output side (closest to Motor Reversing Relay) of the 35A Manual Reset Circuit Breaker. Tighten the Circuit Breaker Output Stud not to exceed 23 in-lbs (3 Nm)
 - g. Slide the insulated boot over the Circuit Breaker terminal connection
 - h. Coat the Ring Terminal of the Battery Positive Power Wire.
 - i. Install the Insulated Terminal Boot on the Battery Positive Power Wire Ring Terminal.
 - j. Install the Battery Positive Power Wire Ring Terminal to the input side (Closest to Battery Energy Source Positive Terminal) of the 35A Manual Reset Circuit Breaker. Tighten the Circuit Breaker Output Stud not to exceed 23 in-lbs (3 Nm)
 - k. Slide the insulated boot over the Circuit Breaker terminal connection
 - l. Install the Circuit Breaker to the mount location using 8-32X5/8" Phillips/pan head bolts. Tighten fasteners not to exceed 19 in-lbs (3 Nm)
 - m. Install Battery Positive Wire Ring Terminal to the positive terminal on the Chassis Lead Acid Battery
6. Install the Ground
 - a. Install Power Supply Harness Ground Wire Ring Terminal to the Negative Post on the Lead Acid Battery
7. Test System Operation