

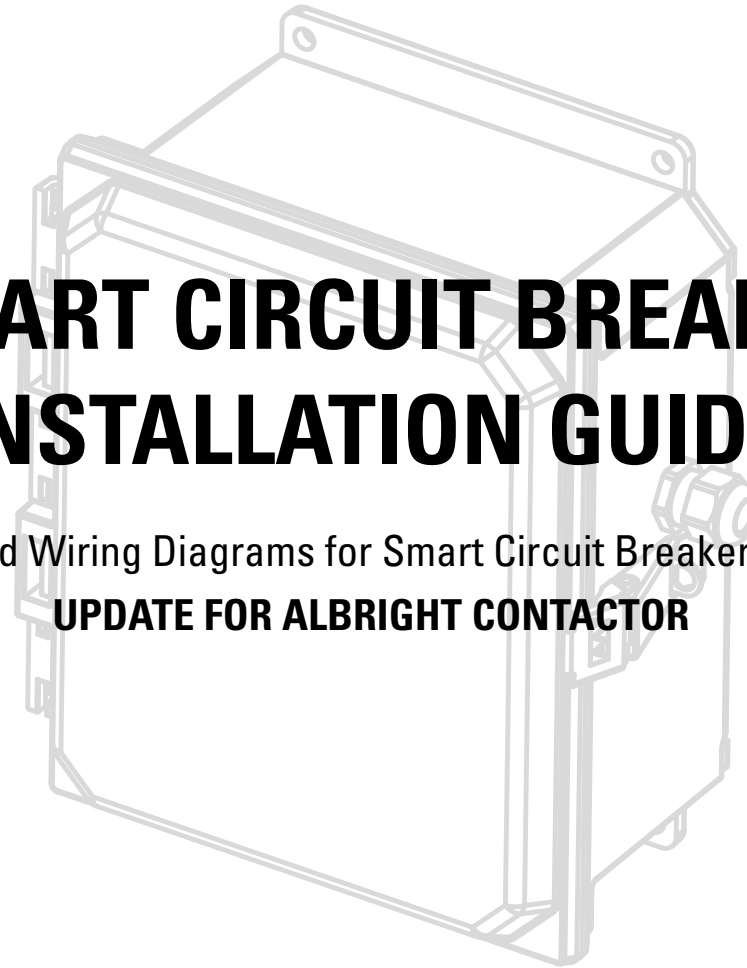

SMART CIRCUIT BREAKER INSTALLATION GUIDE

Installation Requirements and Wiring Diagrams for Smart Circuit Breaker with Motor Reversing Relay
UPDATE FOR ALBRIGHT CONTACTOR



Part #: 105627

Revised: 03/20/26 - WLH



Table of Contents

Electric Kit, S2S w/ RF & Smart Breaker - w/ RF & Shield..... 1

Electric Kit, S2S w/ RF & Smart Breaker - Pre-Wired..... 2

RF & Smart Breaker - Pre-Wired / Diagram 3

RF & Smart Breaker & Switch - Pre-Wired / Diagram 4

Safety Requirements & Required Tools 5

Specifications of Roll-Rite Smart Circuit Breaker Assembly: (P/N 104148)..... 6

Installation and Preventative Maintenance Requirements..... 7-8

Installation Orientation 9

Wiring Diagram for Roll-Rite Smart Circuit Breaker with Motor Reversing Relay & Rocker Switch (Right Side Uncover)..... 10

Wiring Diagram for Roll-Rite Smart Circuit Breaker with Motor Reversing Relay & Rocker Switch (Left Side Uncover) 11

Wiring Diagram for Roll-Rite Smart Circuit Breaker with RF & Key Fob (Right Side Uncover)..... 12

Wiring Diagram for Roll-Rite Smart Circuit Breaker with RF & Key Fob (Left Side Uncover)..... 13

Installation Recommendations of Roll-Rite Smart Circuit Breaker 14

Installation Instructions for Roll-Rite Smart Circuit Breaker..... 15

Installation Instructions for Roll-Rite Smart Circuit Breaker..... 16

Installation Instructions for Roll-Rite Smart Circuit Breaker..... 17

Installation Instructions for Roll-Rite Smart Circuit Breaker..... 18



INSTALLATION GUIDE

Smart Circuit Breaker

ITEM	PART #	DESCRIPTION	QTY
1	109947	Electric Kit, S25 w/ RF & Smart Breaker - Pre-Wired	1
2	109940	Relay, RF Reciever w/ Positive Flag Terminal	1
3	10685	COVER FOR 10690 RELAY	1
4	19801	Key Fob, 6 button Wireless for Black Control Box & Single Function Remote	1
5	101407	Key Chain, Retractable with Logo	1
6	18701	Bolt, 1/4" x 1/2" Button Hex Drive	2

Electric Kit, S2S w/ RF & Smart Breaker - w/ RF & Shield

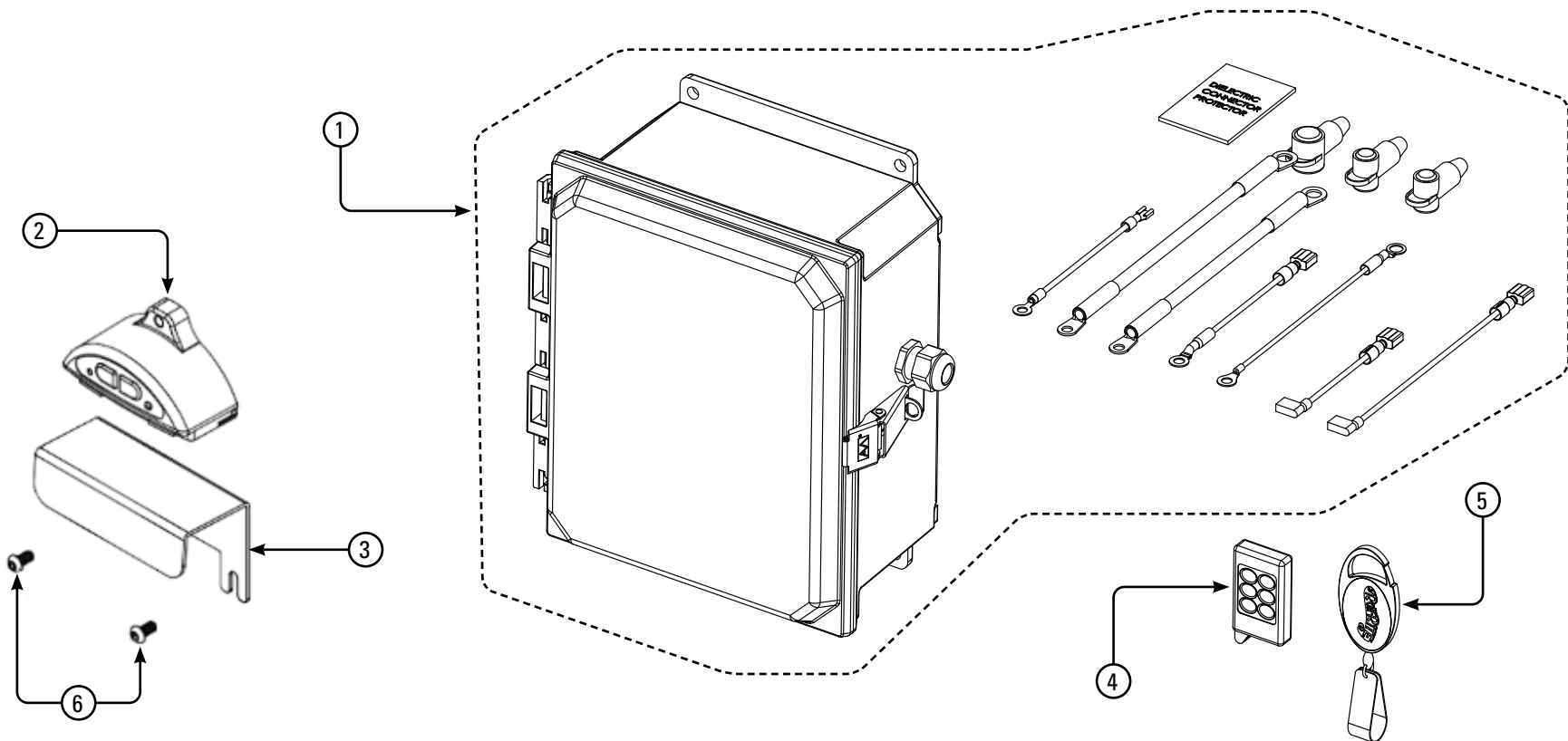



INSTALLATION GUIDE

Smart Circuit Breaker

ITEM	PART #	DESCRIPTION	QTY
1	109474	Nut, 3/8" Wiz Nut	2
2	18242	Bolt, 3/8" - 16 x 1 1/8" Button Head	1
3	101550	Cable Gland - PG 13.5, 6-12mm cable diameter	4
4	18700	Bolt, 1/4" x 1" Hex Head Bolt, Grade 5	1
5	18620	Nut, 1/4" Wiz Nut	1
6	18726	Bolt, 8-32 x 5/8" Phillips Pan Head Zinc	4
7	109936	Enclosure, 10 x 8 x 4 Poly Box w/ Holes w/Clear Door	1
8	109934	Backing Plate for 10 x 8 x 4 Enclosure, Machined	1
9	514-9996	REVERSING HIGH AMP SOLENOID	1
10	101474	Circuit Breaker - Smart circuit breaker	1
11	109929	Jumper Wire, 6 AWG Wire / 1/4" Terminal and 3/8" Terminal - Red	1
12	16000	Packet, Dielectric Grease	1
13	109927	Jumper Wire, 6 AWG Wire w/ 1/4" Terminal and 3/8" Terminal - Black	1
14	514-9921	4" Black 10 gauge Jumper with 1/4 Eyelet	1
15	109937	Nut, Flange - 5/16" - 18 Zinc	2
16	16204	Boot, 8 - 2 AWG, 0.73" TOD, RED	1
17	16213	Boot, 8 - 2 AWG, 0.55" TOD, RED	1
18	16206	Boot, 8 - 2 AWG, 0.55" TOD, Black	1
19	109948	Jumper Wire BLACK, 16 AWG, 6" Length w/ 1/4" Ring Terminal and 1/4" Spade	1
20	109949	Jumper Wire BLACK, 16 AWG, 8" Length w/ 1/4" Ring Terminal and 5/16" Ring	1
21	109950	Jumper Wire BLUE, 16 AWG, 4.5" Length w/ 90° Deg Flag and 1/4" Spade	1
22	109951	Jumper Wire GREEN, 16 AWG, 8" Length w/ 90° Deg Flag and 1/4" Spade	1
23	107152	Screw, Pan Head Phillips, 10 - 32 1/2" Long	2
24	18215	Bolt 5/16" - 18 x 1" Button Head	1

Electric Kit, S2S w/ RF & Smart Breaker - Pre-Wired

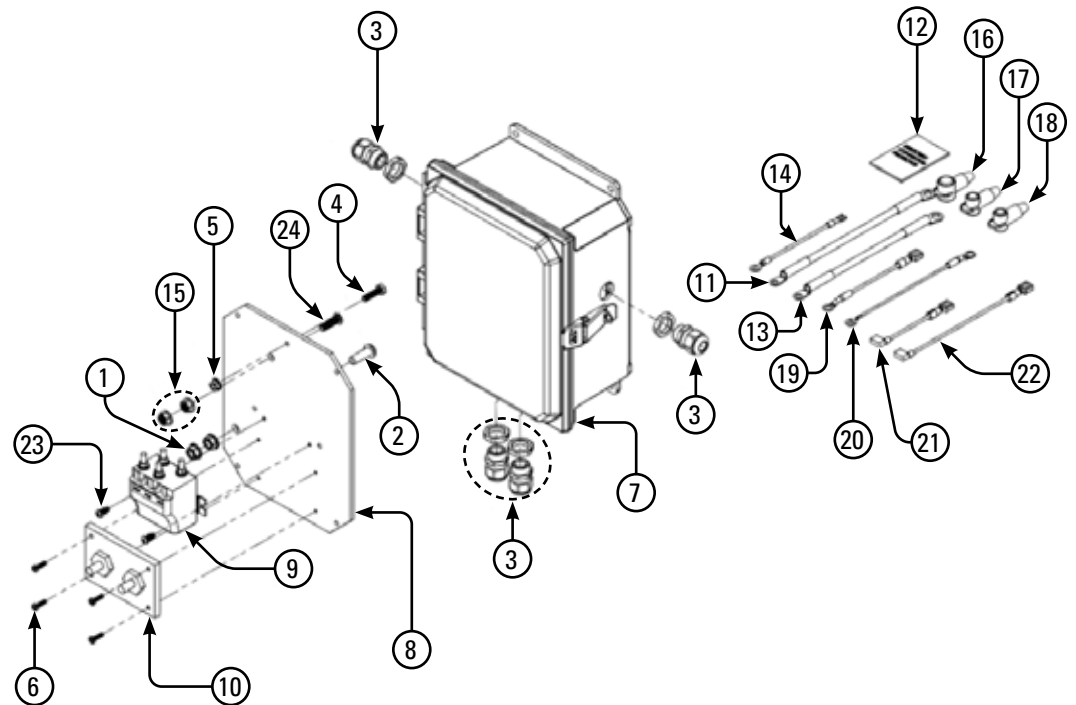



RF & Smart Breaker - Pre-Wired / Diagram

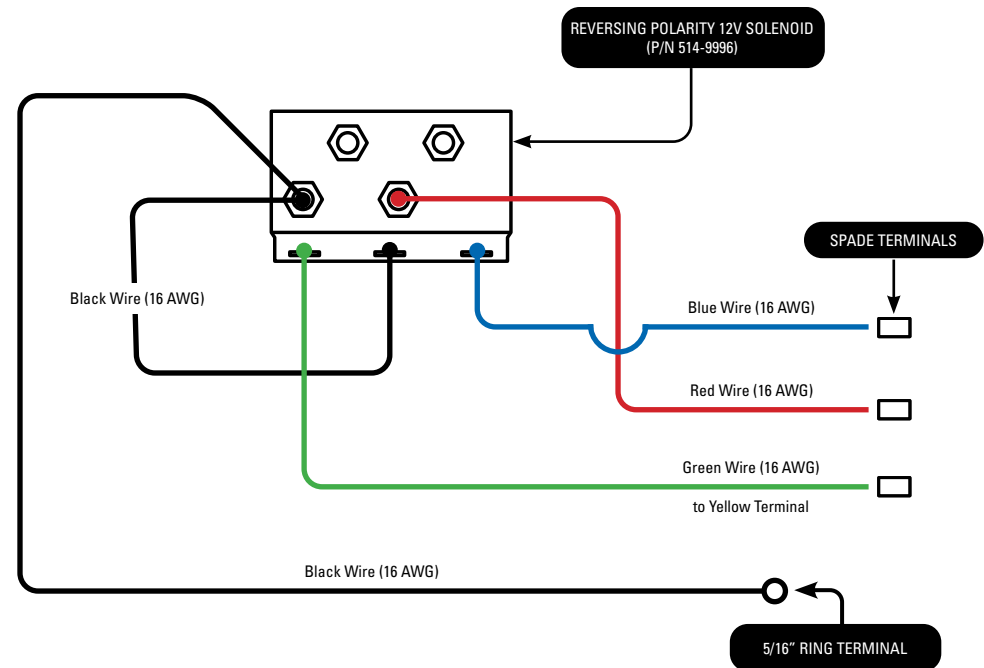
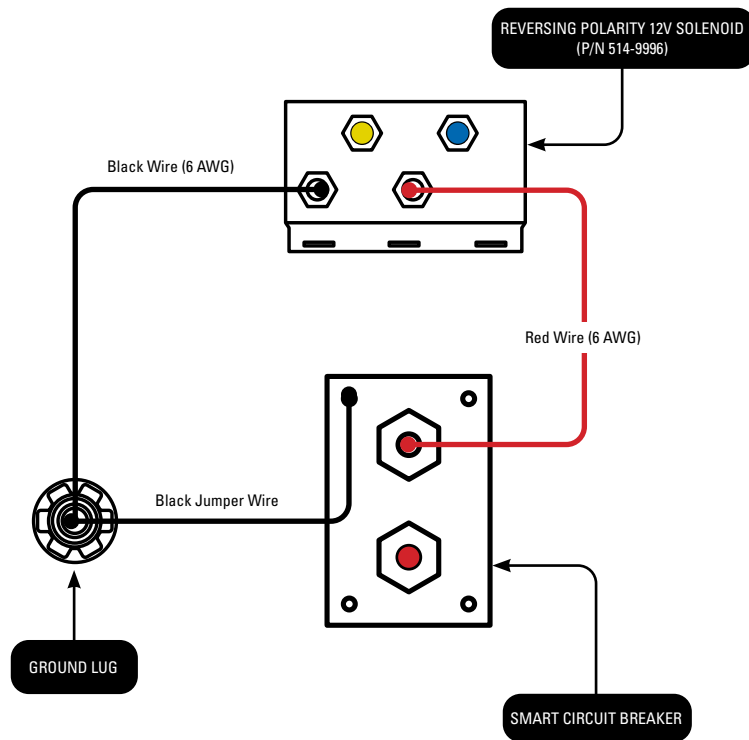



INSTALLATION GUIDE

Smart Circuit Breaker

RF & Smart Breaker & Switch - Pre-Wired / Diagram

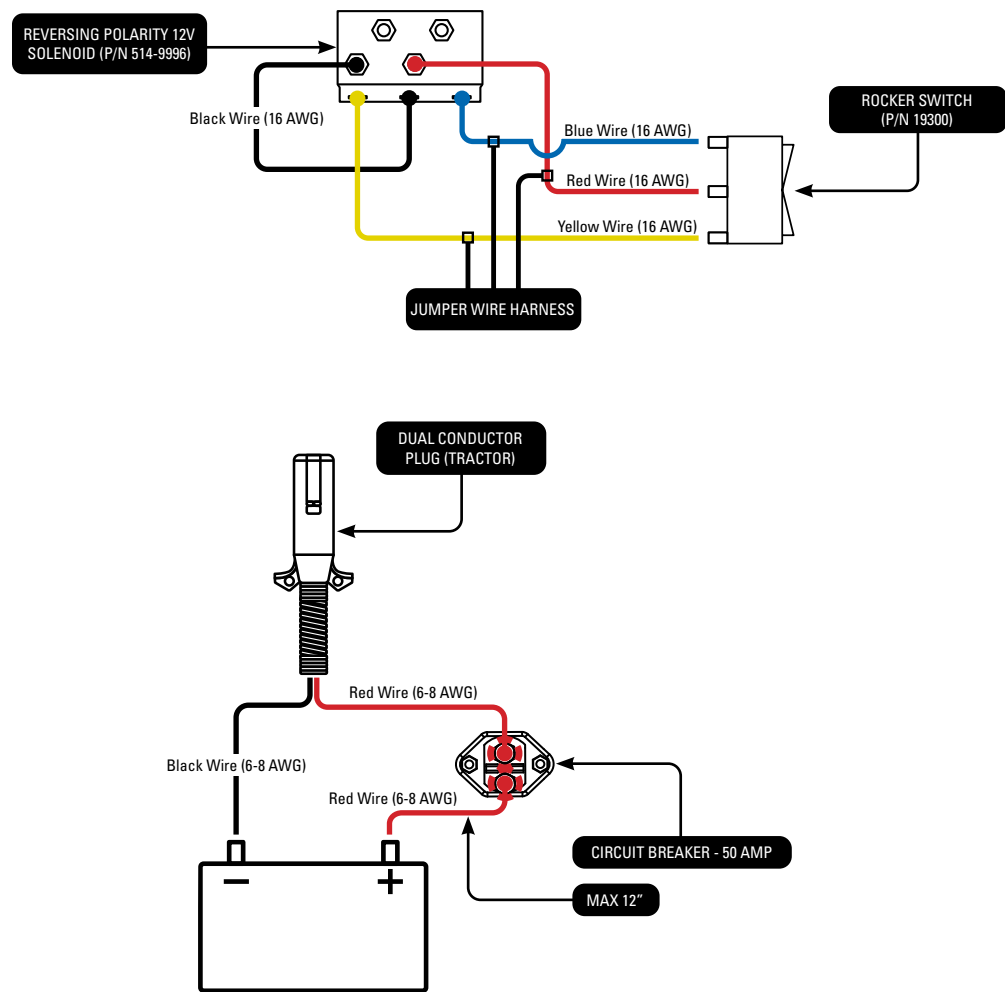
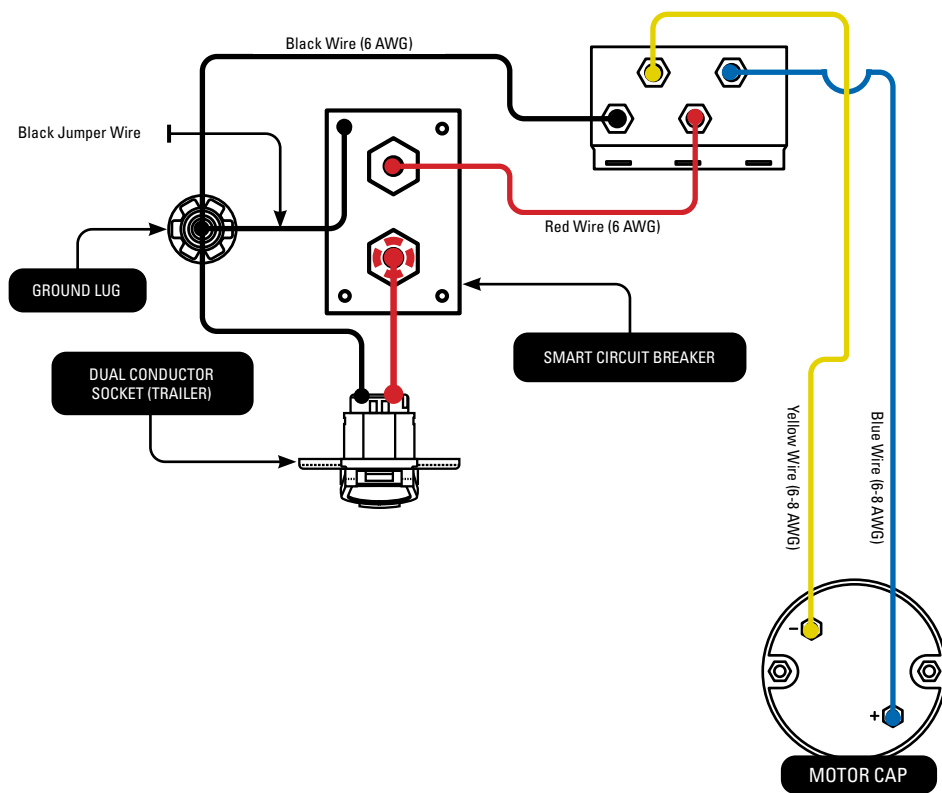



Safety Requirements & Required Tools



Failure to comply with requirements outlined in this document may result in serious injury or property damage

The following requirements shall be met when installing or servicing electrical components in Roll Rite Automated Tarp Systems:

- All connections to vehicle battery systems, vehicle battery chargers, and external power supplies shall be disconnected during all installation procedures
- Prior to installing wiring on positive terminals, check voltage on all wires and connection points using a voltmeter.
- The following personal protective equipment shall be worn at all times while installing components:
 - » Safety Glasses or Prescription Glasses with Side Shields
 - » Steel or Composite Toe Protective Shoes

Tools and Equipment Required for Installation

- The following tools are required for installation of electrical components •
- Torque Wrench with range between 20 in lbs to 150 in lbs
 - Nut Driver Set
 - Wire Cutters up to 2 AWG size wire
 - Wire Insulation Stripping Tool for wire size range from 2 to 8 AWG
 - Wire Insulation Stripping Tool for wire size range from 16 to 18 AWG
 - Wire Terminal Crimping Tool for wire size range from 2 to 8 AWG
 - Wire Terminal Tool for wire size range from 16 to 18 AWG
 - Heat Gun for application of heat shrink insulation
 - Multi-meter with DC voltage measurement capability
 - Tie Straps
 - Vehicle Chassis Wiring insulated c-clamps capable of carrying 2 to 8 AWG wiring

Operation of Roll-Rite Smart Circuit Breaker Assembly W/ Mechanical Relay

The Smart Circuit Breaker Assembly consist of is a Solid State DC Contactor Kit and a Motor Reversing Relay. The assembly provides an overcurrent shutdown which safeguards the electric tarp system by limiting the amount of time the motor can exert stall torque. Failure to install in accordance with the requirements in this document may result in unintended release of battery energy storage, bodily injury, and property damage.

Features of Roll-Rite Smart Circuit Breaker Assembly W/ Mechanical Relay

The Solid State Contactor are contained within an anodized aluminum case and enclosed in clear poly-box mountable enclosure. A LED statues indicator light depicts a solid ON mode when Contactor is on and operating normally, or displays a flashing mode when the Contactor automatically turns off as the result of a fault condition. Fault shut down protection within the device includes the following: Loss of Ground, Over-Current, Under-Voltage, and Over-Temperature. After a fault condition, the module will turn back ON within 10 seconds.



Specifications of Roll-Rite Smart Circuit Breaker Assembly

Fig. 1 - Smart Breaker DC Contactor Kit

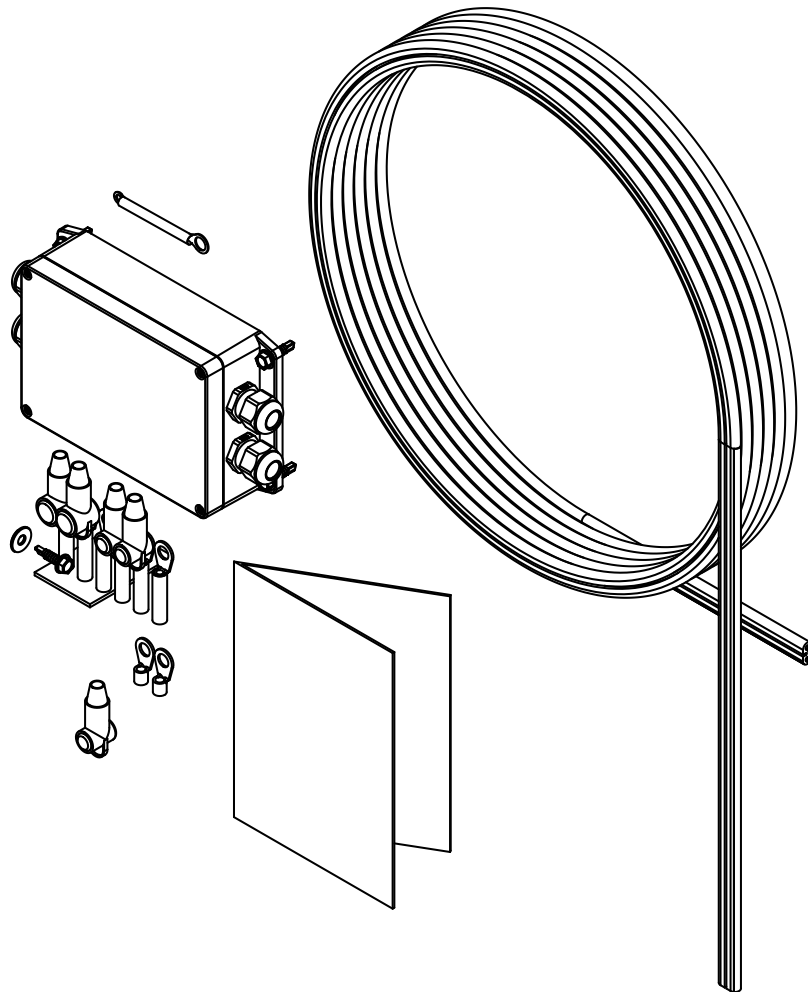

MAXIMUM CURRENT RATING	100 AMPS	
ON-RESISTANCE AT MAXIMUM TEMP	2.2 MILLIOHMS	
OPERATING VOLTAGE RANGE	+7.5 TO +20.0 VOLTS	
CASE MAXIMUM TEMPERATURE	185 DEGREES FAHRENHEIT (85 CELSIUS)	
LOW BATTERY VOLTAGE TRIP	+7.25 TO +7.5 VDC FOR 250 MILLISECONDS	
LOSS OF GROUND TRIP	250 MILLISECONDS	
OVER-CURRENT TRIP	100% TO 110% OF RATED AMPERAGE FOR 500 MILLISECONDS	
LOGIC POWER CURRENT DRAW		
	STATUS LED OFF	80 MILLIWATTS
	STATUS LED ON	150 MILLIWATTS
TURN-ON DELAY	25 MILLISECONDS	
TURN-OFF DELAY	25 MILLISECONDS	
POWER TERMINALS	3/8-16 THREADED STAINLESS STEEL STUDS	



Installation and Preventative Maintenance Requirements

- The Smart Circuit Breaker shall be installed on a vertical plane and enclosed within a mountable Poly Enclosure. See Figure One. NOTE: This is the only approved installation orientation for the Roll-Rite Smart Circuit Breaker.
- Four surface mounting locations are provided on the Smart Circuit Breaker. All four locations shall be utilized in the installation using the provided four 8-32 x 5/8" fasteners (P/N 18726). Position the Smart Circuit Breaker onto the Aluminum Plate and locate it below the large center hole. The locating holes will align with four threaded holes on the Aluminum plate. Torque each 8-32 x 5/8" screw to 1.7 ft-lbs at each location.
- Four corner thru holes are located on the Aluminum Backing Plate. All four locations shall be used in the installation using the provided #4 x 3/8" screws (P/N 103818). Position the Aluminum Backing Plate inside the Poly Enclosure and torque each #4 x 3/8" screw to 0.5 ft.-lbs.
- Power Wiring Harness in accordance with Installation Instructions and Wiring Diagram.
 - » Minimum 8 AWG Two Conductor Wire and Maximum 4 AWG Two Conductor Wire shall be used.
 - » Terminals shall be installed on 4-8 AWG wire such that no current carrying strands are exposed after crimp has been applied.
 - » Properly sized crimping tool (4-8 AWG) shall be used to connect wires to terminals.
 - » Heat shrink or appropriate insulated tape shall be used to seal terminals to 4-8 AWG wire insulation.
 - » Minimum dielectric strength of harness shall be no less than 0.833 kV.
 - » Maximum voltage drop across crimp shall be less than 4mV at 14VDC/100A.
- Jumper Wiring Harness's in accordance with Installation Instructions and Wiring Diagrams.
 - » Wire Gage (14 -16 AWG) shall be used for Smart Breaker Ground Jumper.
 - » Properly sized crimping tool (14/16 AWG) shall be used to connect Ground Jumper Wire Terminal Ends.
 - » Terminals shall be installed 14/16 AWG such that no current carrying strands are exposed after crimp has been applied.
 - » Heat shrink or appropriate insulated tape shall be used to seal terminals to wire 14/16 AWG wire insulation.
 - » Maximum voltage drop across crimped terminals shall be less than 7mV at 14 VDC/35A.
- All terminals shall be coated with dielectric grease prior to installation.
- Insulated **Terminal Boots** shall be installed on both positive High Current Terminals in accordance with Installation Instructions. See Wiring Diagram, Note A.
- Route all electrical wires into and out from the Smart Circuit Breaker in a manner that will avoid wire insulation chafing, pinching, and wear from other items on the truck chassis or wear from the environment.
- Inspect the terminals of the Roll Rite Smart Circuit Breaker every six months.
 - » Remove the Insulated Terminal Boots, inspect and replace if damaged.
 - » Remove and clean all electrical current carrying connections.
 - » Reapply dielectric grease and reinstall in accordance with the Installation Instructions.
- The Roll Rite 50A Circuit Breaker shall be installed in accordance with the Installation Requirements and the Wiring Diagram reference.
 - » The mounting surface shall be chosen to prevent contact between terminals and chassis components. A Minimum clearance of 2 inches (50 mm) between the Circuit Breaker terminals and any surface or object. See Wiring Diagram, Note A
 - » Insulated Boots must be installed on Circuit Breaker terminal connections. See Wiring Diagram, Note A
 - » Circuit Breaker shall be installed in the orientation shown.



Installation and Preventative Maintenance Requirements

- The Roll Rite Motor Reversing Relay shall be installed in accordance with the Installation Requirements and the Wiring Diagram reference.
 - » Inspect the terminals of the Motor Reversing Relay every six months.
 - » Remove the Insulated Terminal Boots, inspect and replace if damaged.
 - » Remove and clean all electrical current carrying connections.
 - » Reapply dielectric grease and reinstall in accordance with the Installation Instructions.

Switch Harness (Rocker Switch)

- Maximum Wire Gage 14 AWG. Minimum Wire Gage 16 AWG.
- Use Insulated Wire Terminals for S1, S2, and Switch Power, Forward and Reverse.
- Use Insulated Ring Terminal for Switch Power connection to B+.
- Properly sized crimping tool (14/16 AWG) shall be used to connect wires to terminals.
- Terminals shall be installed 14/16 AWG such that no current carrying strands are exposed after crimp has been applied.
- Heat shrink or appropriate insulated tape shall be used to seal terminals to wire 14/16 AWG wire insulation.
- Switch Harness minimum dielectric strength between leads shall be no less than 0.833 kΩ with switch installed.
- Maximum voltage drop across crimped terminals shall be less than 7mV at 14 VDC/35A.

Motor Wiring Harness

- Minimum 8 AWG Two Conductor Wire and maximum 4 AWG Two Conductor Wire shall be used.
- Terminals shall be installed on 4-8 AWG wire such that no current carrying strands are exposed after crimp has been applied.
- Properly sized crimping tool (4-8 AWG) shall be used to connect wires to terminals.
- Heat shrink or appropriate insulated tape shall be used to seal terminals to 4-8 AWG wire insulation.
- Minimum dielectric strength of motor harness shall be no less than 0.833 kΩ.
- Maximum voltage drop across crimp shall be less than 4mV at 14VDC/100A.

Power Wiring Harness

- Minimum 8 AWG Two Conductor Wire and Maximum 4 AWG Two Conductor Wire shall be used.
- Terminals shall be installed on 4-8 AWG wire such that no current carrying strands are exposed after crimp has been applied.
- Properly sized crimping tool (4-8 AWG) shall be used to connect wires to terminals.
- Heat shrink or appropriate insulated tape shall be used to seal terminals to 4-8 AWG wire insulation.
- Minimum dielectric strength of motor harness shall be no less than 0.833 kΩ.
- Maximum voltage drop across crimp shall be less than 4mV at 14VDC/100A.

Keep this document for future reference.



Installation Orientation

Fig 2. - Orientation of the Roll-Rite Smart Circuit Breaker Assembly with Poly Box Enclosure.

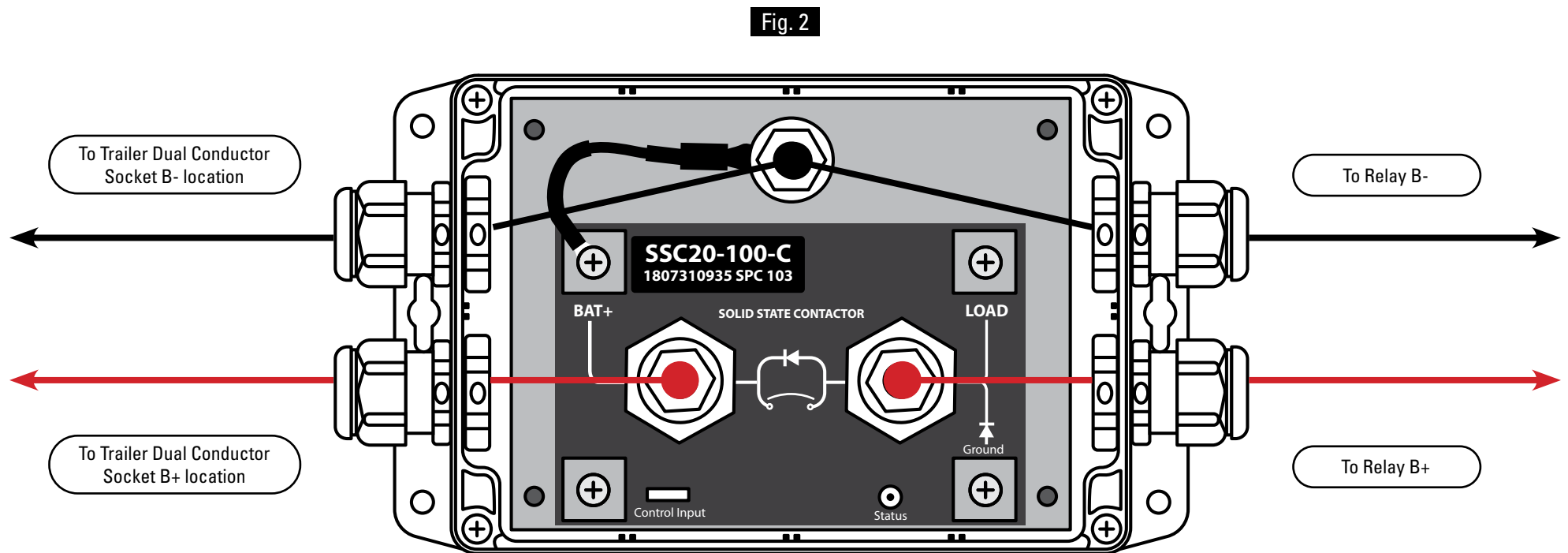



INSTALLATION GUIDE

Smart Circuit Breaker

Wiring Diagram for Roll-Rite Smart Circuit Breaker with Motor Reversing Relay & Rocker Switch (Right Side Uncover)

(For Reference Only, Follow Installation Instructions for Required Procedure)

RIGHT SIDE UNCOVER: M1 Motor to M1 Relay / M2 Motor to M2 Relay

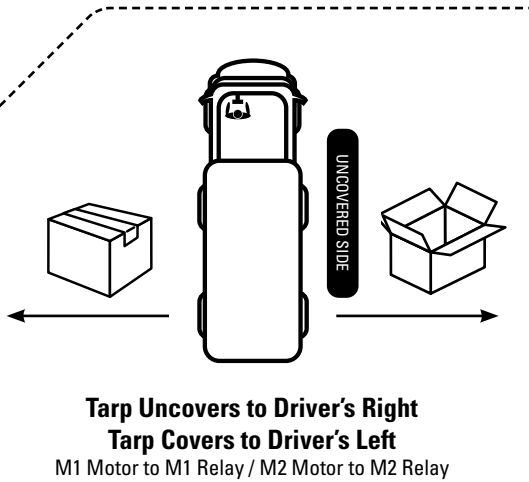
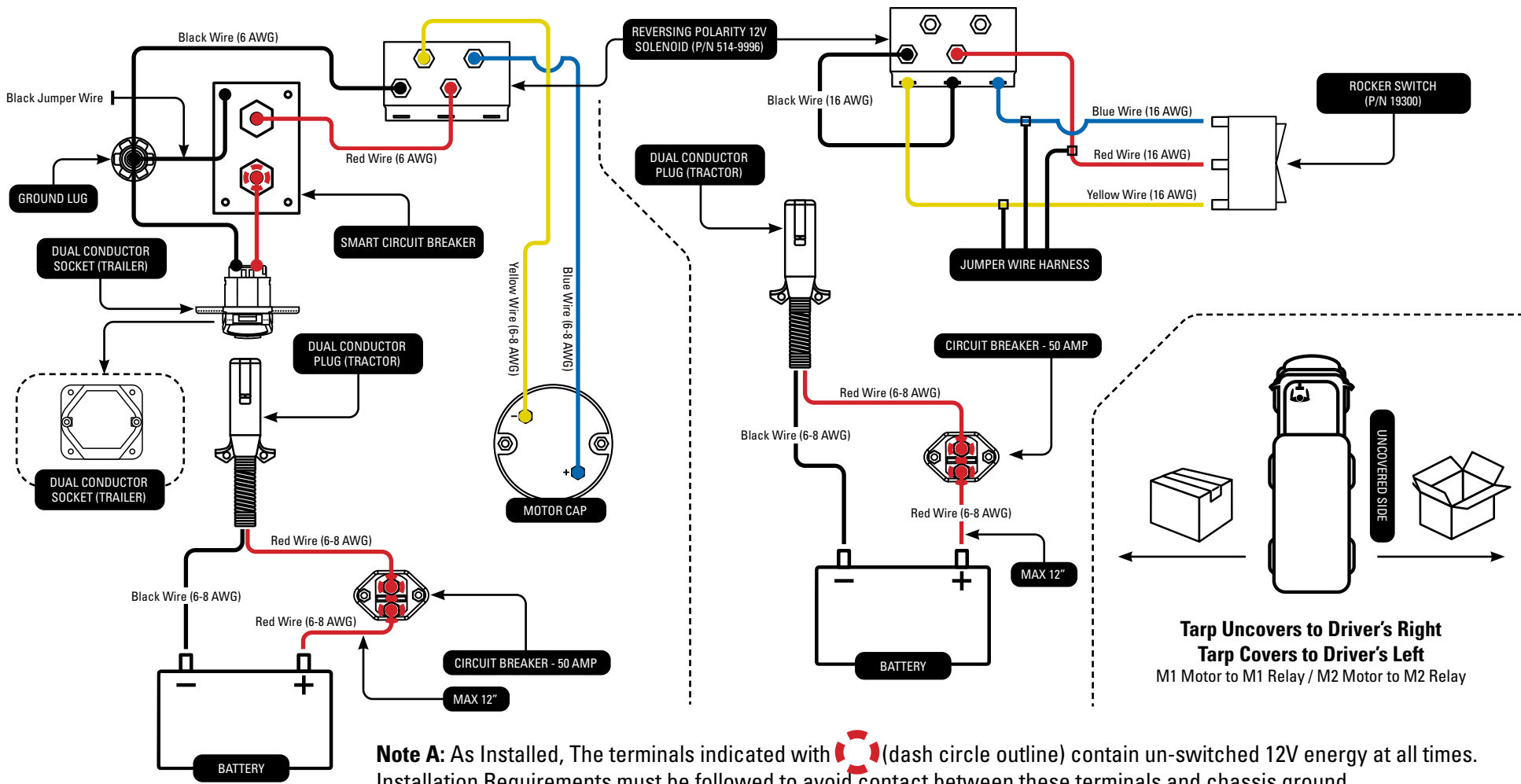



INSTALLATION GUIDE

Smart Circuit Breaker

Wiring Diagram for Roll-Rite Smart Circuit Breaker with Motor Reversing Relay & Rocker Switch (Left Side Uncover)

(For Reference Only, Follow Installation Instructions for Required Procedure)

LEFT SIDE UNCOVER: M2 Motor to M1 Relay / M1 Motor to M2 Relay

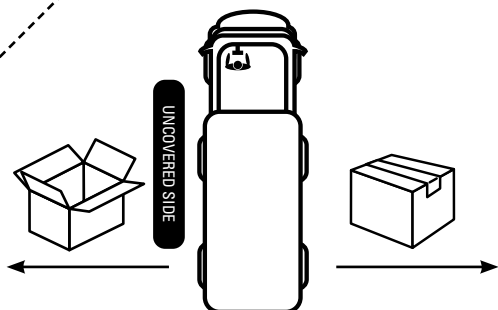
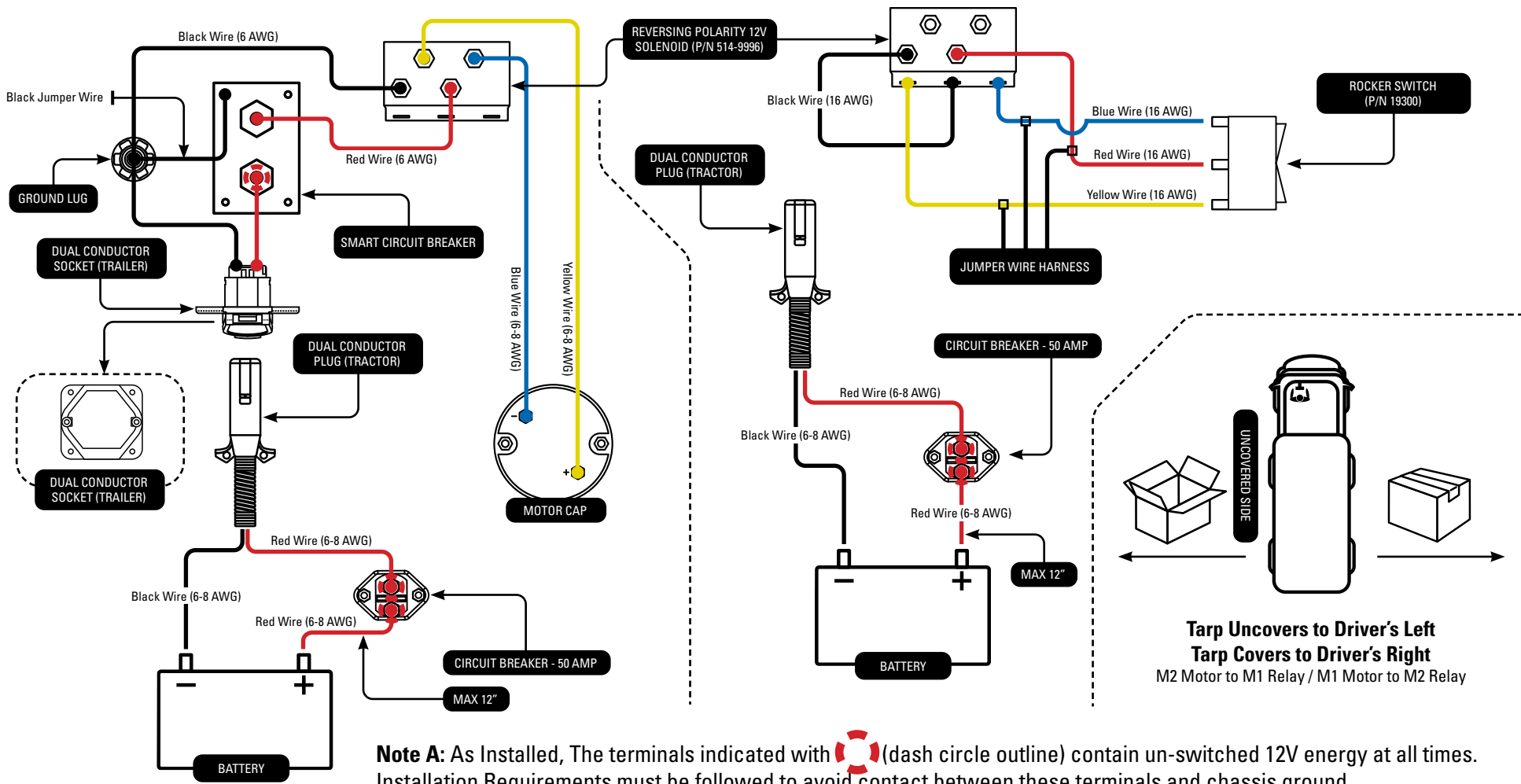

M2 Motor to M1 Relay / M1 Motor to M2 Relay

Note A: As Installed, The terminals indicated with  (dash circle outline) contain un-switched 12V energy at all times. Installation Requirements must be followed to avoid contact between these terminals and chassis ground.



INSTALLATION GUIDE

Smart Circuit Breaker

Wiring Diagram for Roll-Rite Smart Circuit Breaker with RF & Key Fob (Right Side Uncover)

(For Reference Only, Follow Installation Instructions for Required Procedure)

RIGHT SIDE UNCOVER: M1 Motor to M1 Relay / M2 Motor to M2 Relay

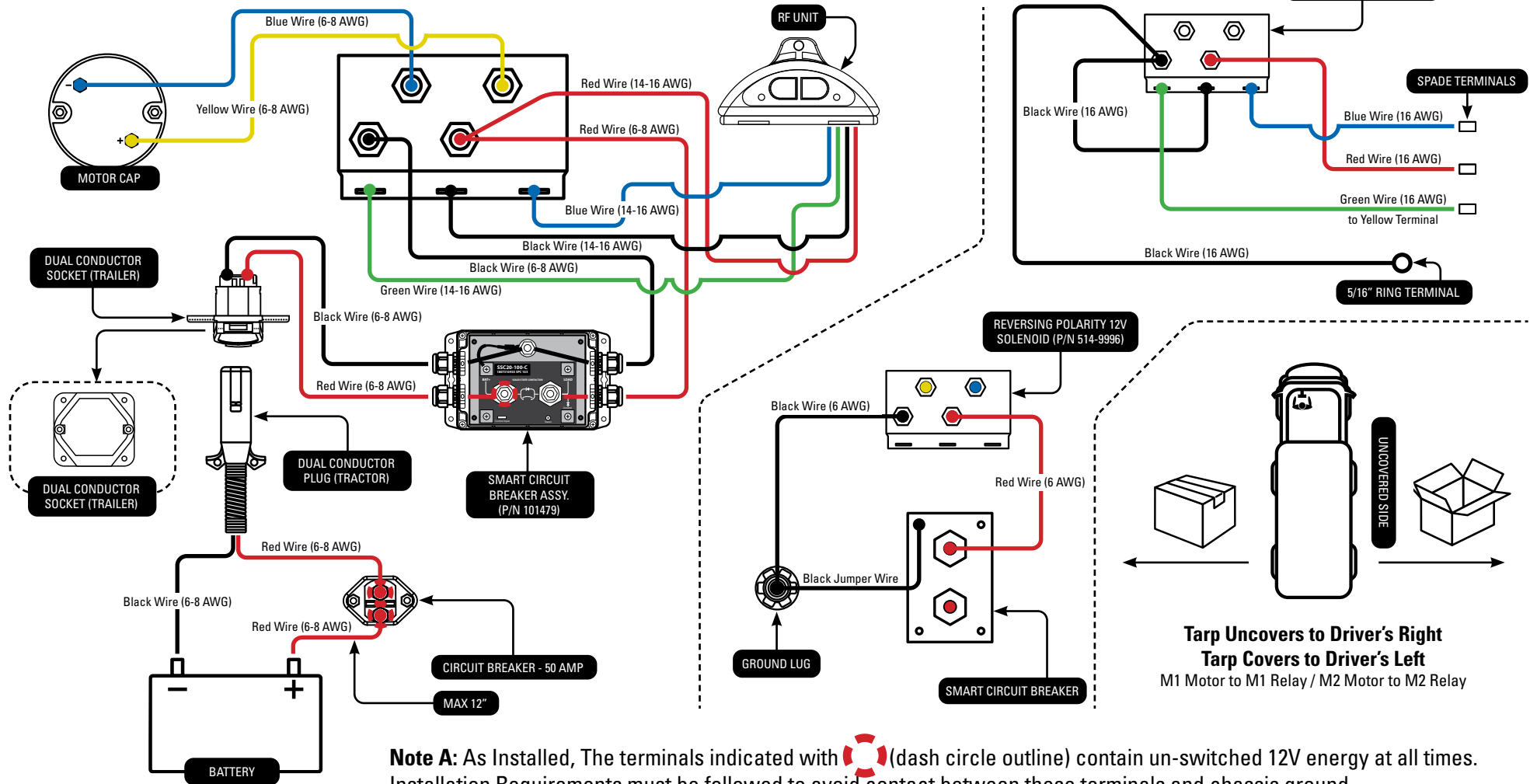



INSTALLATION GUIDE

Smart Circuit Breaker

Wiring Diagram for Roll-Rite Smart Circuit Breaker with RF & Key Fob (Left Side Uncover)

(For Reference Only, Follow Installation Instructions for Required Procedure)

LEFT SIDE UNCOVER: M2 Motor to M1 Relay / M1 Motor to M2 Relay

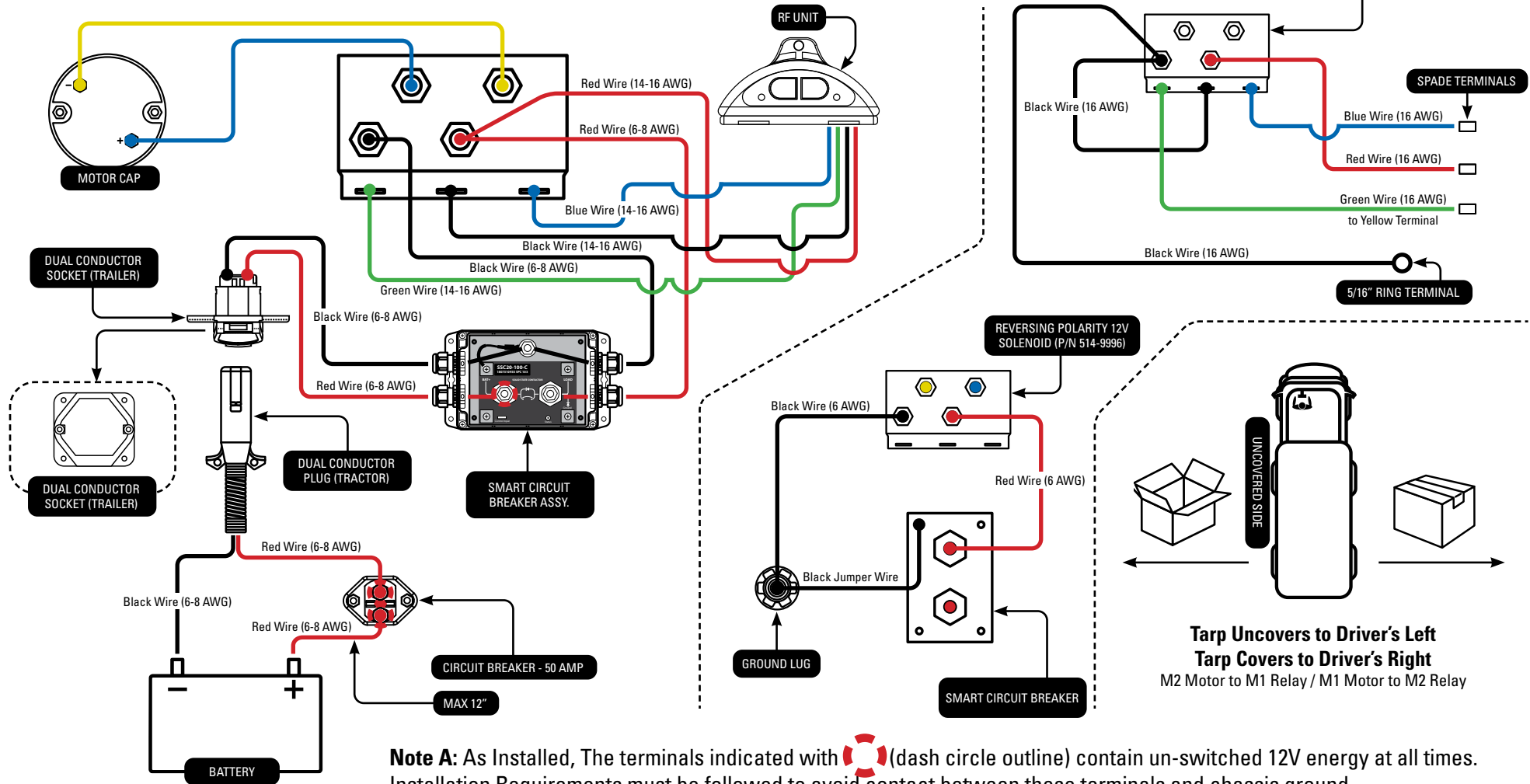

Note A: As Installed, The terminals indicated with  (dash circle outline) contain un-switched 12V energy at all times. Installation Requirements must be followed to avoid contact between these terminals and chassis ground.



Installation Recommendations of Roll-Rite Smart Circuit Breaker

- Install the Roll Rite Smart Circuit Breaker in a location that it will not be directly impacted by road debris, sand, gravel, and road salt.
- **DO NOT USE THE ROLL-RITE SMART CIRCUIT BREAKER IF THE DEVICE IS DROPPED FROM A HEIGHT GREATER THAN 3 FEET (91CM).**
- All electrical terminals shall be coated with dielectric grease, Synthetic NLGL Grade 2 or equivalent.
- Remove negative electrical terminals of all chassis batteries prior to installation of Roll Rite components.

Installation Instructions for Roll-Rite Smart Circuit Breaker

1. Prior to installation of the Roll Rite Smart Circuit Breaker

- a. Install the Roll Rite Automated covering system, including the Electric Gear Motor.
- b. Install and Route the Electric Gear Motor Supply Wire (4 or 6 gage, two conductor wire) to the pre-determined Motor Reversing Relay Installation Location, consistent with the Installation Requirements.

2. Install the Electrical Connections to the Relay, consistent with the Installation Requirements

- a. Gear Motor Connection
 - II. Install the Appropriate Poly Box Enclosure on the Chassis Mounting Location.
 - III. Assure the mounting location meets the Installation and Preventative Maintenance Requirements in this document.
 - IV. Install the 1/4" -20 x 1 fasteners to two mounting locations of the Motor Reversing Relay. Torque hand tight not to exceed 8 ft-lb (11 Nm).
 - V. Place Insulated Terminal Boots on the Electric Gear Motor Supply Harness over the ring terminal connections for M1 and M2 that will be attached to the Motor Reversing Relay.
 - VI. Apply dielectric grease to the M1 and M2 Ring Terminals on the Electric Gear Motor Supply Harness.
 - VII. Apply dielectric grease to the Motor Reversing Relay Terminals, M1 and M2.
 - VIII. Connect the Electric Gear Motor Supply Harness to the Terminals, M1 and M2.
 - IX. Apply torque to the M1 and M2 terminal studs. Do not exceed 70-85 in lbs - DO NOT EXCEED 7ft lbs (9.4Nm).
 - X. Slide the Insulated Terminal Boot over the electrical connection, fully covering the terminal connection.
- b. Rocker Switch Connection (if applicable)
 - I. Apply dielectric grease to the Motor Reversing Relay Spade Terminal S1 and S2.
 - II. Apply dielectric grease to the Rocker Switch Ring Terminal B+ connection.
 - III. Apply dielectric grease to the Connector Terminals of the Rocker Switch Harness.
 - IV. Place the Rocker Terminal Switch Harness Flag / Spade Receiver Connectors on the Motor Reversing Relay Spade Terminals S1 and S2.
 - V. Place the Rocker Terminal Switch Ring Connectors on the Motor Reversing Relay Post Terminal location B+.
 - VI. Install the Rocker Switch into the locating slot on the Poly Box Enclosure with "OPEN" facing up. See wire diagram and installation instructions.



Installation Instructions for Roll-Rite Smart Circuit Breaker

- c. RF Switch Connection (if applicable)
 - I. Apply dielectric grease to the Motor Reversing Relay Spade Terminal S1 and S2.
 - II. Apply dielectric grease to the RF Module Ring Terminals B- (GND) & B+ (Vbat+).
 - III. Place the RF Module Harness Flag/Spade Connectors on the Motor Reversing Relay Spade Terminals S1 and S2.
 - IV. Place the RF Module Harness Black Ring Terminal Connector on the Motor Reversing Relay Stud Terminal B-. See wire diagram for use with RF Module.
 - V. Place the RF Module Harness Red Ring Terminal Connector on the Motor Reversing Relay Stud Terminal B+. See wire diagram for use with the RF Module.
 - VI. Position the RF Module into the locating grooves on top of the Motor Reversing Relay.
 - VII. Assure the mounting location meets the Installation and Preventative Maintenance Requirements in this document.
 - VIII. Install the 1/4"-20 x 1 fasteners to one mounting location on the RF Module. Torque hand tight not to exceed 8 ft-lb (11 Nm).

3. Assemble, Locate and Install the Smart Circuit Breaker Poly Box Enclosure

- a. Locate the clear Poly Enclosure Box. Install the Cable Glands into the four locations on the sides of Poly Enclosure.
- b. Locate the Aluminum backing plate. Pass the 3/8-16 X 1 1/8" bolt thru the center clearance hole and position two 3/8" Wiz nuts on the threads.
- c. Orient and install the Aluminum backing plate into the Poly Enclosure Box. The 3/8" bolt threads & Wiz nuts will face out. Secure the plate to the enclosure using the provided #4 X 3/8" long screws.
- d. Locate the Smart Circuit Breaker 101474. Remove the clear foil from the insulating material behind the Smart Circuit Breaker. Correctly position the Smart Circuit Breaker onto the Aluminum backing plate and secure it using the provided 8-32 X 5/8" long screws.
- e. Assure the mounting location of the Smart circuit Breaker Poly Box Enclosure meets the Installation and Preventative Maintenance Requirements in this document.
- f. Secure the assembled Poly Box containing the Circuit Breaker on a vertical surface between the Dual Pole Conductor & Motor Reversing Relay Enclosure. See Diagram below.

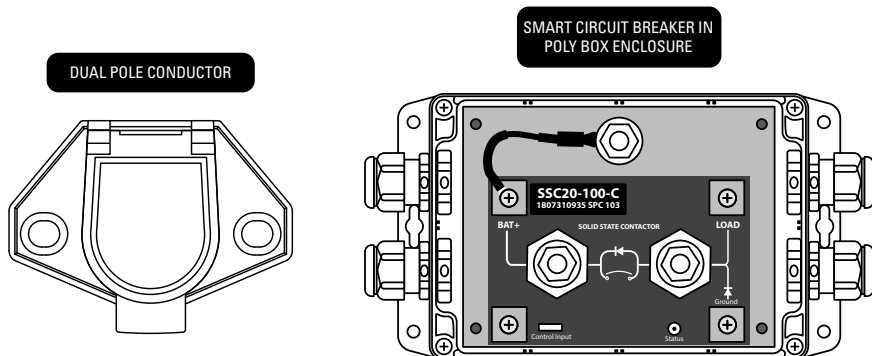

NOTE: Prior to Completing next step, assure the chassis power and ground are not connected to the lead acid battery. Failure to follow this direction may result in arc current.

It is required to remove and isolate the source of Electrical power before installing the Smart Circuit Breaker.

Failure to complete this action may result in hazardous Condition resulting in bodily injury or property damage.



Installation Instructions for Roll-Rite Smart Circuit Breaker

4. Chassis Ground Connection (B-)

- a. Locate the clear Poly Enclosure Box. Install the Cable Glands into the four locations on the sides of Poly Enclosure.
- b. Minimum 8 AWG Two Conductor Wire and Maximum 4 AWG Two Conductor Wire shall be used to connect the Ground connection from the Dual Pole Conductor to the Smart Circuit Breaker and from the Smart Circuit Breaker to the Motor Reversing Relay. See Wiring Diagram
- c. Terminals shall be installed on 4-8 AWG wire such that no current carrying strands are exposed after crimp has been applied.
- d. Properly sized crimping tool (4-8 AWG) shall be used to connect wires to terminals.
- e. Heat shrink or appropriate insulated tape shall be used to seal terminals to 4-8 AWG wire insulation.
- f. Minimum dielectric strength of harness shall be no less than 0.833 kΩ.
- g. Maximum voltage drop across crimp shall be less than 4mV at 14VDC/100A.
- h. Determine the (4-8 AWG) wire length required for proper electrical connection to the Dual Pole Socket Conductor and Motor Reversing Relay.
- i. Cut the (4-8 AWG) wires to length and feed separated ends through the Cable Glands. Strip only enough wire insulation to install ring terminals. Insert bare wire into ring terminals and crimp securely.
- j. Minimum 16 AWG Wire and Maximum 14 AWG Wire shall be used to create the short GROUND JUMPER from the Negative Post on the Aluminum Backing Plate to one of the grounding screws located on the face of the Smart Circuit Breaker. See Wiring Diagram
- k. Terminals shall be installed on (14-16 AWG) ground jumper wire such that no current carrying strands are exposed after crimp has been applied.
- l. Properly sized crimping tool (14-16 AWG) shall be used to connect ground jumper wire terminal ends.
- m. Heat shrink or appropriate insulated tape shall be used to seal terminals to (14-16 AWG) wire insulation.
- n. Determine the (14-16 AWG) wire length needed to create the Negative Jumper Wire.
- o. Cut the (14-16 AWG) Jumper wire to length. Strip only enough wire insulation to install ring terminals. Insert bare wire into ring terminals and crimp securely.
- p. Apply Dielectric Grease to all Ground Wire Ring Terminals within the smart circuit Breaker.
- q. Apply dielectric grease to the Motor Reversing Relay B- Terminal.
- r. Secure the Ring terminals to the Ground Post using the supplied Wiz Nuts. Do not exceed 70-85 in lbs - DO NOT EXCEED 7ft lbs (9.4Nm).
- s. Connect the Power Supply Harness Ground Wire to the B- Terminal on the Motor Reversing Relay.
- t. Apply torque to the B- terminal studs. Do not exceed 70-85 in lbs - DO NOT EXCEED 7ft lbs (9.4Nm).

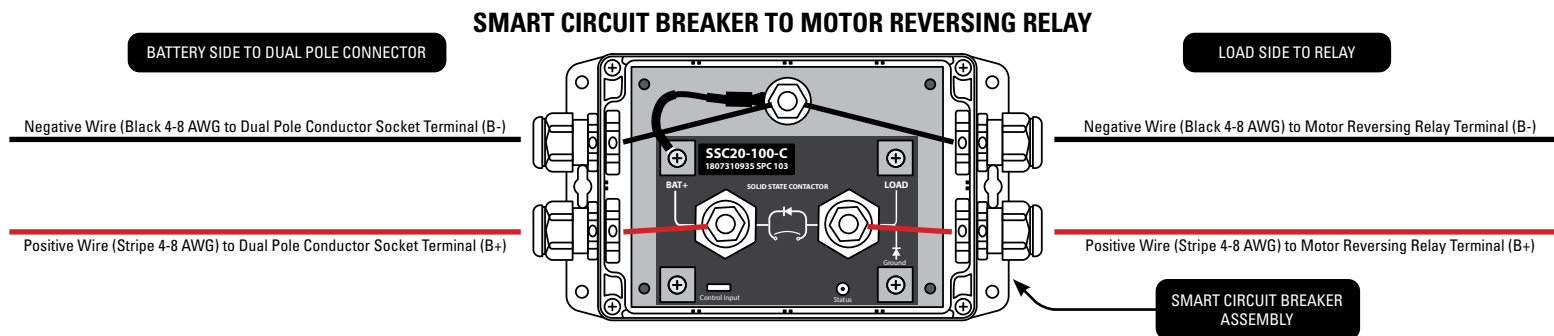



Installation Instructions for Roll-Rite Smart Circuit Breaker

5. Chassis Power Connection (B+)

- a. Minimum 8 AWG Two Conductor Wire and Maximum 4 AWG Two Conductor Wire shall be used to connect the High Current Positive connection from the Dual Pole Conductor to the Smart Circuit Breaker and from the Smart Circuit Breaker to the Motor Reversing Relay. See Wiring Diagram
- b. Terminals shall be installed on 4-8 AWG wire such that no current carrying strands are exposed after crimp has been applied.
- c. Properly sized crimping tool (4-8 AWG) shall be used to connect wires to terminals.
- d. Heat shrink or appropriate insulated tape shall be used to seal terminals to 4-8 AWG wire insulation.
- e. Minimum dielectric strength of harness shall be no less than 0.833 kΩ.
- f. Maximum voltage drop across crimp shall be less than 4mV at 14VDC/100A.
- g. Determine the (4-8 AWG) wire length required for proper electrical connection to the Dual Pole Socket Conductor and Motor Reversing Relay.
- h. Cut the (4-8 AWG) wires to length and feed separated ends through the Cable Glands. Strip only enough wire insulation to install ring terminals. Insert bare wire into ring terminals and crimp securely
- i. Insulated Terminal Boot (P/N 16204) shall be installed on both positive High Current Terminals in accordance with Installation Instructions.
- j. Apply dielectric grease to the Motor Reversing Relay B+ Terminal.
- k. Connect the Power Supply Harness High Voltage Wire to the B+ Terminal on the Motor Reversing Relay.
- l. Apply torque to the B+ terminal studs. Do not exceed 70-85 in lbs - DO NOT EXCEED 7ft lbs (9.4Nm).
- m. Slide the Insulated Terminal Boot over the electrical connection at the Motor Reversing Relay B+ terminal fully covering the terminal connection.

6. Position Clear Poly Cover onto Enclosure and secure with the provided screws

7. Install the 50A Circuit Breaker

- a. The 50A Circuit Breaker is a surface mount device. Mount such that face of Circuit Breaker and reset switch are easily accessible.
- b. Choose a location to mount the 50A Circuit Breaker which ensures at least 2" clearance between the terminals and any other surface.
- c. Coat the Circuit Breaker terminals with dielectric grease.
- d. Coat the Positive Wire Ring terminal with dielectric grease.
- e. Tighten the Circuit Breaker Output Stud not to exceed 23 in-lbs. (3 Nm).
- f. Slide the insulated boot over the Circuit Breaker terminal connection.
- g. Coat the Ring Terminal of the Battery Positive Power Wire.
- h. Install the Insulated Terminal Boot on the Battery Positive Power Wire Ring Terminal.
- i. Install the Battery Positive Power Wire Ring Terminal to the input side (Closest to Battery Energy Source Positive Terminal) of the 50A Circuit Breaker. Tighten the Circuit Breaker Output Stud not to exceed 23 in-lbs. (3 Nm).
- j. Slide the insulated boot over the Circuit Breaker terminal connection.
- k. Install the Circuit Breaker to the mount location using 8-32X5/8" Phillips/pan head bolts. Tighten fasteners not to exceed 19 in-lbs. (3 Nm).
- l. Install Battery Positive Wire Ring Terminal to the positive terminal on the Chassis Lead Acid Battery.



INSTALLATION GUIDE

Smart Circuit Breaker

Installation Instructions for Roll-Rite Smart Circuit Breaker

8. Install the Ground

- a. Install Power Supply Harness Ground Wire Ring Terminal to the Negative Post on the Lead Acid Battery.



Assure that the Dual Conductor Trailer Plug (power and ground polarity) is the same as the Dual Conductor Socket (power and ground polarity) **The Smart Circuit Breaker is not reverse battery protected.** VBat+ from Battery must connect to battery side positive post on Smart Circuit Breaker. Failure to follow this direction will permanently damage device.

Verify (VBat+) Polarity Exist between Dual Pole Conductor Plug & Socket.

The Smart Circuit Breaker is not Reverse Battery Protected.

VBat+ from Battery must connect to battery side positive post on Smart Circuit Breaker.

Failure to follow this direction will damage device.

9. Test System Operation



Do not weld on vehicle while Smart Circuit Breaker is installed or Module may be damaged. If welding is necessary, disconnect the load and battery terminals before welding.

